

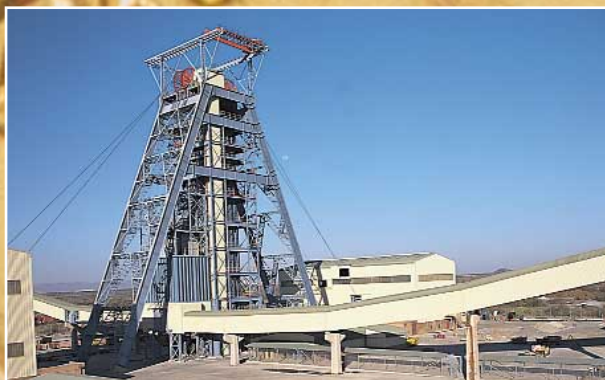

Bredel

**Engineering
the future**

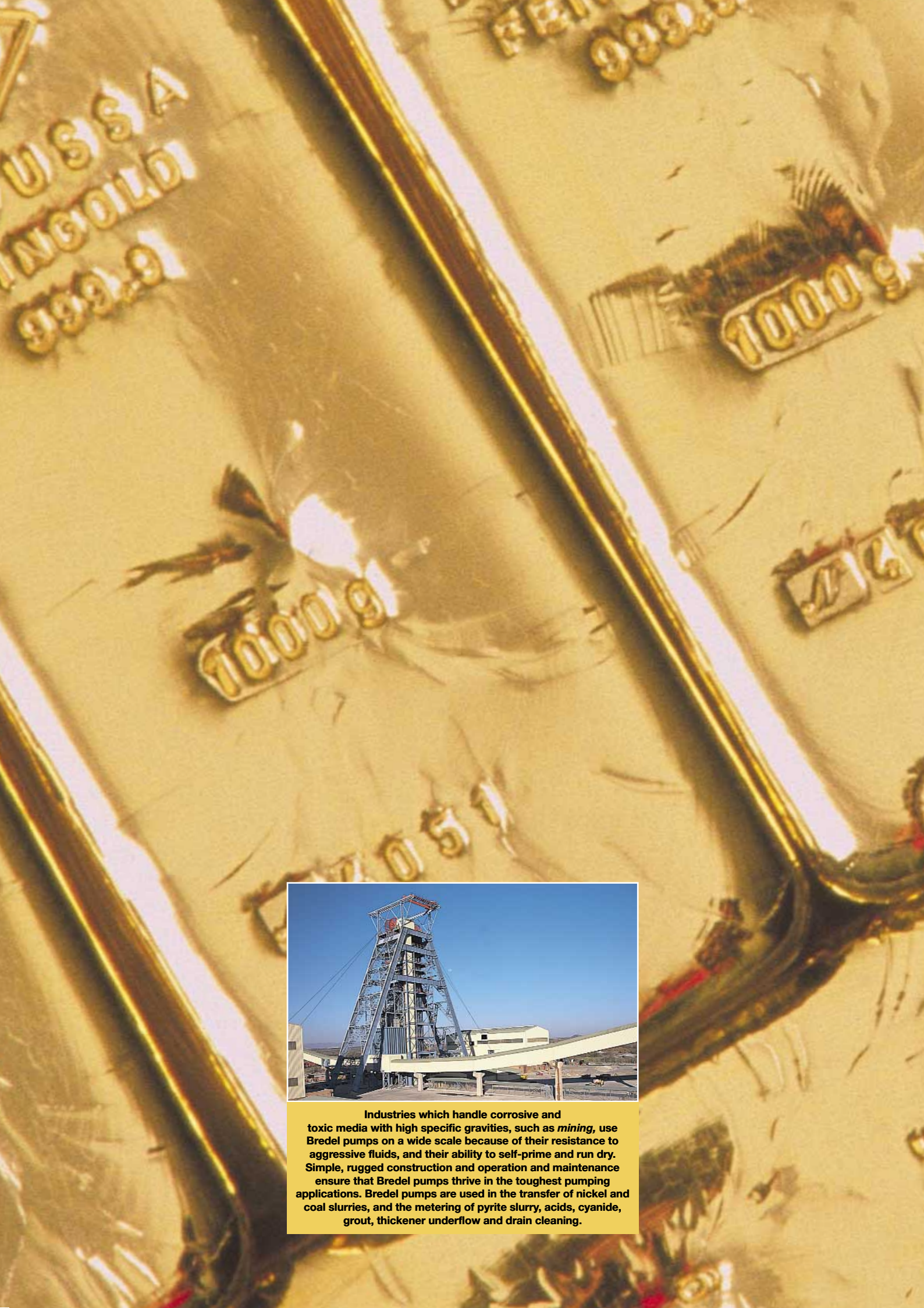

Industries which handle corrosive and toxic media with high specific gravities, such as *mining*, use Bredel pumps on a wide scale because of their resistance to aggressive fluids, and their ability to self-prime and run dry. Simple, rugged construction and operation and maintenance ensure that Bredel pumps thrive in the toughest pumping applications. Bredel pumps are used in the transfer of nickel and coal slurries, and the metering of pyrite slurry, acids, cyanide, grout, thickener underflow and drain cleaning.

Bredel: World leaders in high-pressure hose pumping

Bredel: Engineering the future of hose pumping

Bredel engineering created an entirely new type of pump, the high-pressure hose pump. Its patented technology attained the impossible; the unbeatable simplicity, reliability and low maintenance needs of peristaltic pumping brought to high-flow, high-pressure duties.

Today nearly 50,000 Bredel hose pumps are at work around the world solving the toughest pumping problems at flow rates up to 80 cubic metres/hour (350 US gpm) and pressures up to 16 bar (230 psi). Hose pumps are the future, and they are the fastest growing pump type.

What makes high-pressure hose pumps the fastest growing pump type?

Tens of thousands of pump users have discovered that there isn't a more rugged and reliable pump than a Bredel. The simplicity of its operating principle can never be beaten.

- easy to install and simple to operate, Bredel hose pumps are rated for continuous use, 24 hours a day, 7 days a week.
- abrasive slurries, corrosive acids, gaseous liquids and shear-sensitive products can all be pumped with confidence.
- excellent ability to handle aggressive, high viscosity, high density products.
- safe dry-running. The Bredel pump does not need fluid in the hose to cool or lubricate it, and can suck air intermittently or continuously without damage.
- contamination-free, the fluid is contained entirely within its hose, separated from the pump. No other type of positive

displacement pump offers this unique separation of pump and fluid.

- with no seals, valves, diaphragms, glands, immersed rotors, stators or pistons to leak, clog, corrode and replace, Bredel pumps are hygienic, easy to clean and virtually maintenance free. Spares inventory investment and management are dramatically reduced.
- reversibility means fluid can be pumped back to source, saving cost, and making draining-down easy.
- back-flow and siphoning are eliminated, with no valves needed.
- self priming, high suction lift for maximum flexibility of installation.
- output is directly proportional to pump speed and independent of inlet or discharge pressure conditions or fluid viscosity, giving superb metering capabilities.
- the specially compounded food grade lubricant also functions as a coolant and makes Bredel pumps especially quiet-running.
- at the heart of all Bredel pumps is a remarkable precision machined hose, available in abrasion and corrosion resistant materials, including Natural Rubber (NR), EPDM and internationally approved food-grade Buna N (NBR).





Industries handling viscous and abrasive fluids, such as *ceramics*, value the abrasion resistance, low levels of shear damage, and the absence of metallic components of Bredel pumps. Equally important is their ability to handle media such as ceramic slip without aeration where the hose pump's glandless construction prevents air ingress during pumping.

High-precision machined hose element

At the heart of all Bredel pumps is a remarkable composite reinforced hose. The hose is constructed from high quality compounded rubbers, reinforced with four individual layers of braided nylon and finished by high precision machining.

Because rubber is incompressible, nothing is more important to hose pumping than accurate control of occlusion:

- over-compression of the hose stresses both pump and hose. A 1mm variation in wall thickness would reduce hose life by at least 25%, and impose unplanned loads on the pump bearings, reducing both hose and pump life.
- under-compression results in loss of pump efficiency and damaging back-flow which also reduces hose life.

Each Bredel hose is a precision machined component, with unmatched wall thickness and surface finish accuracy ensuring that perfect occlusion is maintained and hose life is maximised.

Bredel is the only hose pump manufacturer to machine its own hoses, and no other manufacturer can match Bredel's experience of configuring pump and hose to precisely meet the flow, pressure and temperature characteristics of any application.

Machined hoses give:

- consistent tolerances
- consistent quality
- consistent shimming
- improved hose life due to reduced friction

Four layers give:

- excellent suction performance
- high pressure capability
- volumetric accuracy
- consistent capacity tolerant to varying suction and discharge conditions
- exceptional performance when handling high viscosity products

Hose construction

- 1 uneven external surface of the hose prior to machining
- 2 precision machined natural rubber outer layer
- 3 four nylon reinforcement layers
- 4 inner liner material available in various chemically resistant rubbers



Hose bore (mm)	Wall thickness (mm)	Tolerance on wall thickness (± mm)	Maximum working pressure (bar-psi)	Burst pressure (bar-psi)	Flow variation over working life
10	10.5	0.40	7.5 - 110	75 - 1090	± 1%
15	10.5	0.40	7.5 - 110	75 - 1090	± 1%
25	14.1	0.20	16 - 230	75 - 1090	± 1%
32	14.5	0.20	16 - 230	70 - 1015	± 1%
40	13.2	0.20	16 - 230	70 - 1015	± 1%
50	15.0	0.20	16 - 230	65 - 940	± 1%
65	17.1	0.20	16 - 230	65 - 940	± 1%
80	21.0	0.25	16 - 230	60 - 870	± 1%
100	22.0	0.25	16 - 230	55 - 800	± 1%

Natural Rubber

Always the first choice. A highly resilient material with excellent abrasion resistance and mechanical strength, is generally resistant to diluted acids and alcohols. Max. liquid temperature 80 °C (175 °F) Min. temperature -20 °C (-5 °F)*

Buna N (NBR)

- Nitrile Butadiene Rubber. FDA and 3A approved. A highly abrasion proof and wear resistant material that is generally resistant to oils, fats, alkalines and detergents and is suitable for a wide range of food applications. Max. liquid temp. 80 °C (175 °F) Min. temperature -10 °C (20 °F)*

EPDM

Excellent chemical resistance especially to concentrated acids, ketones and alcohols. Max. liquid temperature 80 °C (175 °F) Min. temperature -10 °C (20 °F)*

** For details on higher temperature operation, up to 90 °C (195 °F), and precise information on hose chemical compatibility, please consult your Bredel representative.*





Industries which handle viscous slurries, shear-sensitive and abrasive fluids, such as *pulp and paper*, have discovered the benefits of Bredel pumps for the transfer of clay slurry, talcum suspension and pulp, and the metering of adhesive, ink, coatings, pigments and products such as titanium dioxide.

The performance



Bredel Application Engineers around the globe are factory trained, highly experienced, and equipped with Bredel's computerised hose pump sizing program **BRAINS** to accurately specify pump and pipe sizes, layout, speeds, hose material, and every other factor necessary to optimise the efficiency of each installation.

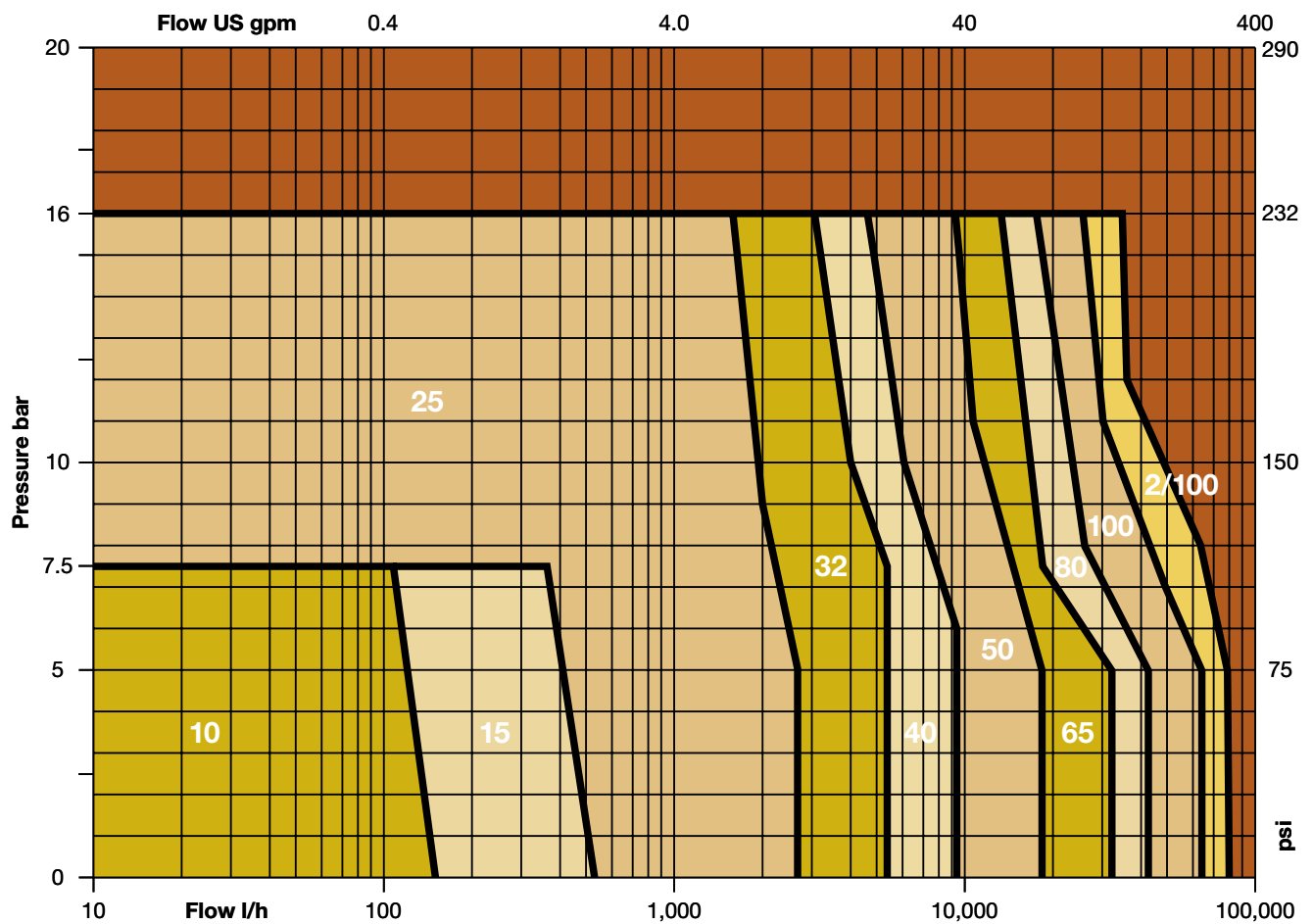
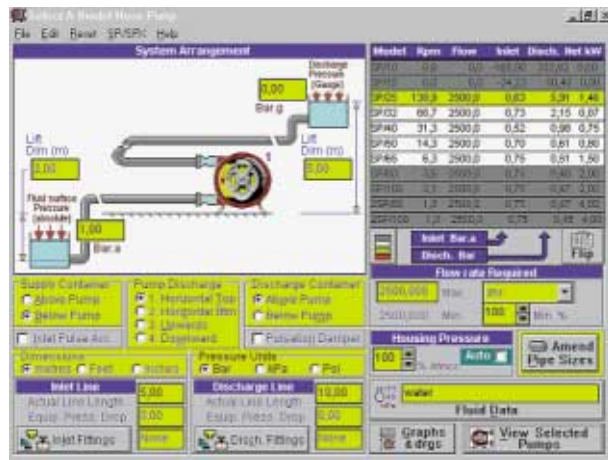



Industries dealing with abrasive and easily damaged media, such as *brewing*, have switched to Bredel pumps on a wide scale because their glandless and valveless construction makes them ideal for sampling and precise metering and dosing. Bredel hose pumps handle diatomaceous earth at all stages of the filtration process, dose yeast into the wort prior to fermentation, pump settled yeast from fermentation vessels, feed settled yeast to filter presses, flush delivery lines and skim off the surface layers of unsettled yeast.

The hose pump



The brilliant new SPX - the future of high-pressure hose pumping

The all-new Bredel SPX creates a new standard for hose pumping with its unique patented direct-coupled design which combines the best features of conventional bareshaft and close-coupled designs.

At the heart of the Bredel SPX direct-coupled design is a large diameter, high-strength, twin-bearing hub integrated into the pumphead. Uniquely, this means that the rotor is always fully, and centrally, supported by its own bearings, unlike a close-coupled design which relies on the gearbox bearings to carry overhanging pumphead loads. The SPX eliminates the coupling and baseplate of a bareshaft design, bringing its footprint and weight below that of a close coupled design. Maintenance and set-up time is also drastically reduced.

There is a choice of an ultra-compact planetary gearbox or conventional helical gearbox. For specialist drive needs, such as petrol or diesel engines, a bare-shaft version of the SPX is available. Hydraulic or pneumatic motors can easily be fitted to the standard SPX with an adaptor available from Bredel.

The gearbox plugs directly into the pumphead, and a unique buffer zone has been created between the pumphead bearings and gearbox bearing, protecting both, and providing early warning of a lubricant seal failure. Up to now, seal failure could result in costly damage to the gearbox or the pump.

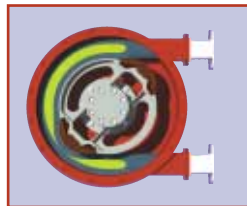
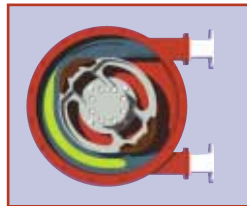
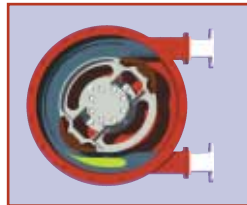
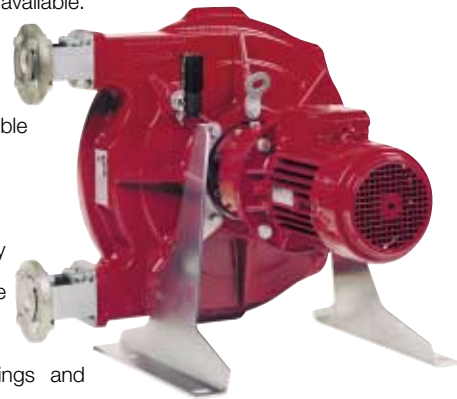

Comparative advantages	Bareshaft	Close-coupled	SPX direct-coupled
<i>Ease of maintenance</i>	•		•
<i>Protected gearbox - lubricant seal in pumphead</i>	•		•
<i>Reliability - bearings in pumphead</i>	•		•
<i>Compact footprint</i>		•	•
<i>Faster installation - no drive alignment</i>		•	•
Total	3	2	5

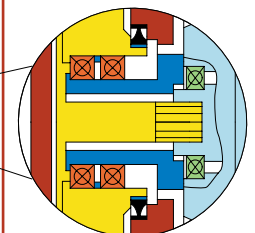
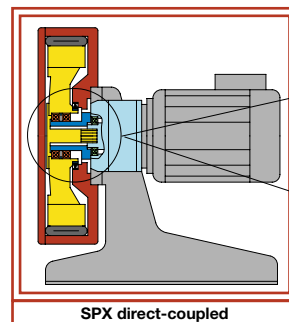
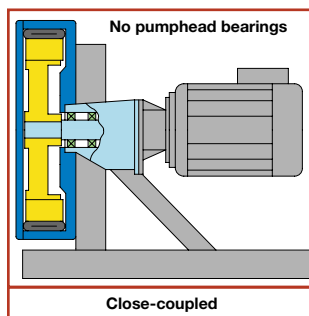
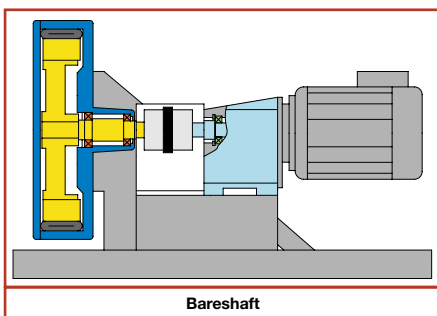

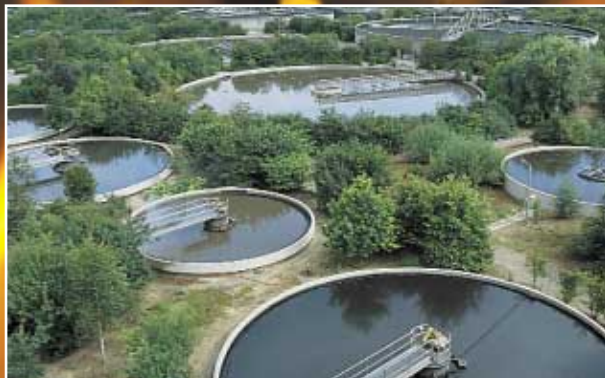

Industries which transfer, sample and meter under arduous conditions, such as *water and waste treatment*, rely on Bredel pumps for sludge thickening, filter-press, digester and centrifuge feed, and pit and lagoon emptying. Bredel pumps capably handle caustic, lime slurry, flocculants, ferric chloride, coagulants, active carbon, aluminium sulphate, magnetite, polyelectrolyte, sodium hypochlorite.

The engineering challenge... and the Bredel solution

Until now, the choice in high-pressure hose pumps has been between bare-shaft (long-coupled) and close-coupled pumps. Bareshaft pumps have lower maintenance needs, and fully protect the drive. Close-coupled pumps are more compact and do not have the cost of a coupling or the need for drive alignment, but the gearbox bearings take all the forces of the pump and the gearbox seals must resist the pressure in the pump casing. The world-standard Bredel SP pumps have always used bareshaft construction because this has been the only way to ensure complete reliability and the lowest maintenance needs and cost.

Now, the new SPX direct-coupled design combines the best features of both designs. The size and simplicity of a close-coupled pump with the reliability and ease of maintenance of a bareshaft design.

No other hose pump combines such a small footprint with a fully protected drive. The gearbox actually plugs directly into the pumphead, creating an innovative buffer zone that provides additional protection to the pump bearings and gearbox.

Simpler hose clamping combined with a powered hose-changing system cuts hose replacement time, and no special tools are required. Access to the case is faster, and corrosion resistance has been improved throughout the design.

Uniquely, in the event of massive overload from a stalled rotor, a computer-calculated undercut shaft will fail safely and predictably, minimising component damage and downtime.

Materials of construction

Description	Material
Pump housing	Cast iron GG25
Cover	Commercial grade mild steel 37
Inspection window	PMMA
Pump rotor	Cast iron GG25
Pressing shoes	Epoxy
Frame	Mild steel, galvanised to 15 microns minimum*
Hose flange brackets	Mild steel, galvanised to 15 microns minimum*
Cover fixings	Mild steel, galvanised*
Motor fixings	Mild steel, galvanised*
Frame fixings	Mild steel, galvanised*
Lubricant seals	Neoprene or Nitrile
Hose	NR, NBR, EPDM

** option of stainless steel available*

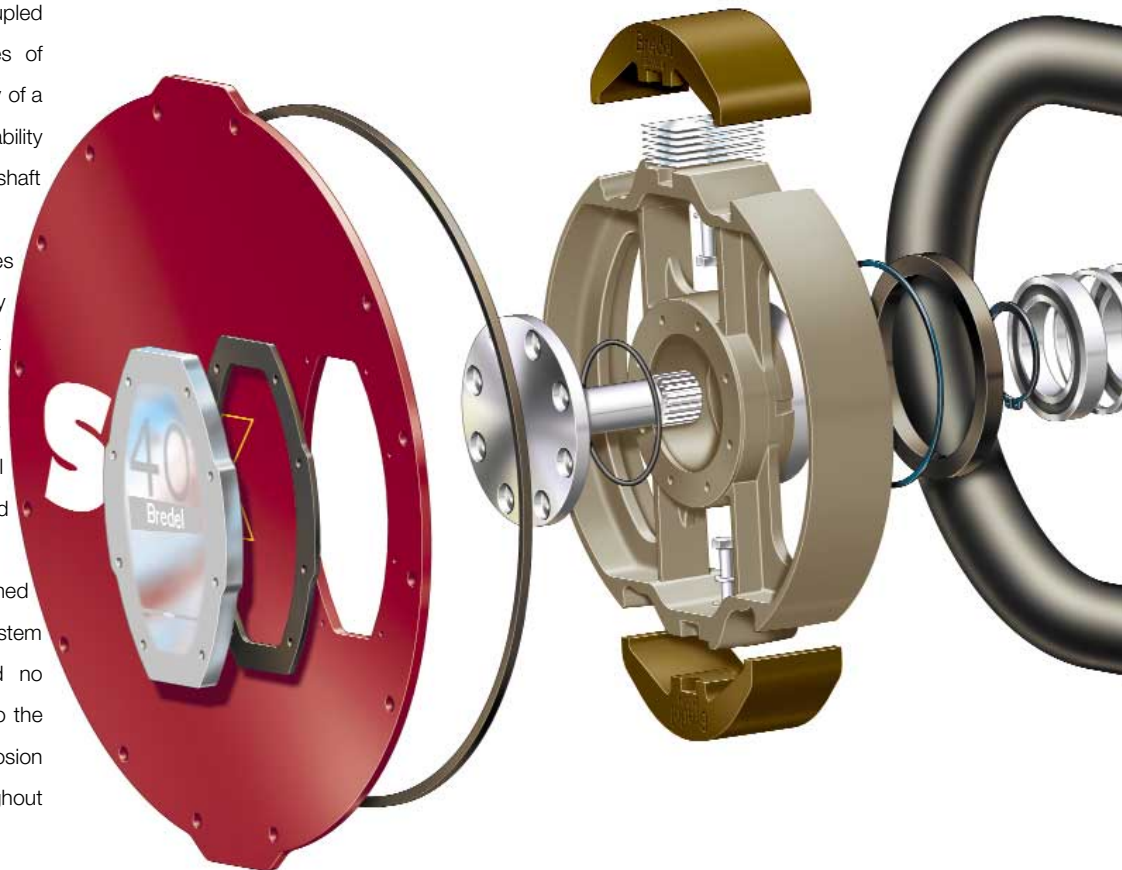

The new direct-coupled SPX: answering the challenge

The benefits of the new SPX

- ultra compact
- rotor fully supported on it's own bearings
- automatic alignment of pump and drive
- low maintenance
- rapid access to shims and pressing shoes
- faster hose changing and improved sealing
- two year warranty
- buffer zone protects gearbox and pump bearings
- unique fail-safe design
- no heavy baseplate necessary
- improved frame design
- increased corrosion resistance
- no cover projections
- no special tools required
- reduced bolt numbers for faster access

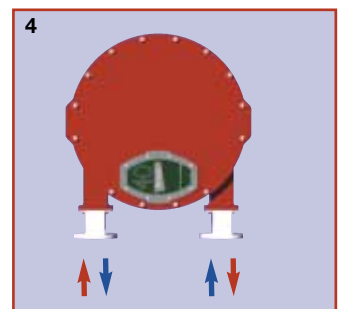
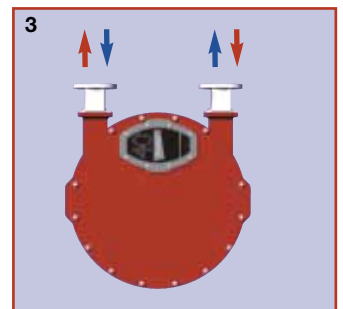
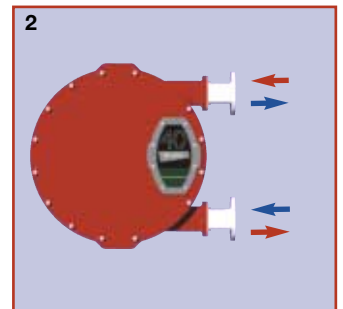
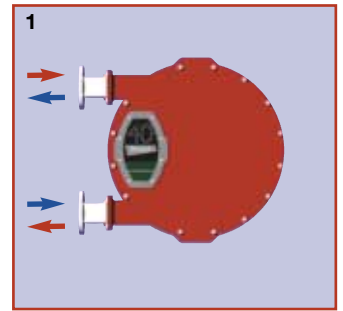
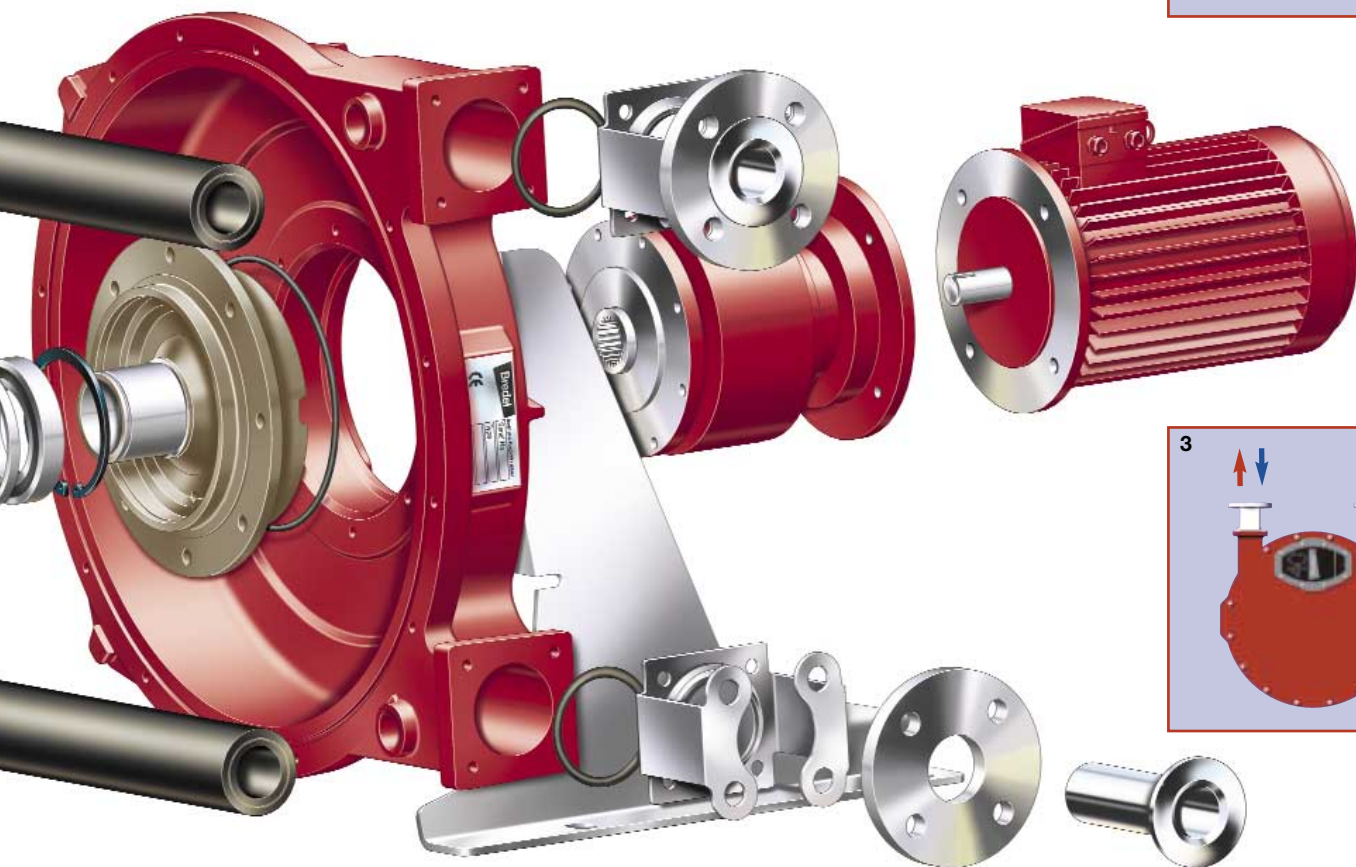

The accessories to fulfill any liquid transfer demand

Discharge Pulsation Damper

This hose pump accessory operates in the discharge line by means of a reinforced flexible hose within a steel cylinder, surrounded by a volume of compressed air. The damper unit can also be used as a pressure relief and injection valve.



The Pulsation Damper

The Pulsation Damper advantages include:

- eliminates up to 90% of the pump discharge pulsations
- protects pump, pipeline and instrumentation
- reduces pipe vibration, hammer and noise
- increases pump performance and hose life
- increases efficiency of the pump installation
- non intrusive, through bore easy to clean
- simple installation, can be mounted both horizontally and vertically
- flange connections in accordance to DIN, ASA/ANSI or JIS

Inlet Pulse Accumulator

The installation of this hose pump accessory on the suction side is only

recommended to eliminate the impulse losses and achieve optimum hose life.

Where the inlet line lengths and pump speed warrant its use, the pulse suppressor assembly must be mounted against the pump inlet flange in the vertical position. Findings show that positive and negative pressure spikes in the suction line during pump operation can be effectively eliminated...resulting in quieter operation and extended hose life. Please contact your representative with application data for a specific recommendation.



Inlet Pulse Accumulator

The lubricant level control

The lubricant level control will switch off the pump in case of high liquid level. Should a pump hose fail, the product will be contained within the pump.

The lubricant level control sensor plugs directly into the breather and senses a high lubricant/product mixture level inside the housing, that activates a contact relay which switches off the pump. An option of a low lubricant level sensor is also available.



The lubricant level control

Clean In place (CIP)

The models 40 and 50 are also available with the option of retracting shoes for non-intrusive cleaning, for CIP-applications. For more information we refer to our separate documentation.



Clean in place (CIP)

Vacuum Assist

For absolute suction conditions and high viscosity fluids, Bredel hose pumps also have the option of vacuum assist to aid hose recovery and increase hose fill capacity.

Bredel

Bredel Hose Pumps B.V.

A member of the Spirax-Sarco Engineering Group

Sluisstraat 7

P.O. Box 47

NL-7490 AA Delden

The Netherlands

Tel.: +31 74 3770000

Fax: +31 74 3761175

Internet: www.bredel.com

Your representative:

The information contained in this document is believed to be correct but Bredel Hose Pumps B.V. accepts no liability for any errors it contains, and reserves the right to alter specifications without notice.

Bredel and SPX are registered trademarks.

Concept and design
Erik Achten Associates
Arnhem, The Netherlands

Bredel: worldwide supplier of industrial high pressure hose pumps

