

**5 ОРТОГОНАЛЬНЫЕ РЕДУКТОРЫ И МОТОР-РЕДУКТОРЫ****Z**

Стр.

5.1	Технические характеристики.....	110
5.2	Обозначение .....	110
5.3	Модели .....	111
5.4	Смазка .....	113
5.5	Радиальные и осевые нагрузки .....	114
5.6	Максимальный крутящий момент, передаваемый при последовательном соединении редукторов.....	115
5.7	Эксплуатационные показатели редукторов серии Z.....	116
5.8	Размеры .....	120
5.9	Аксессуары .....	142

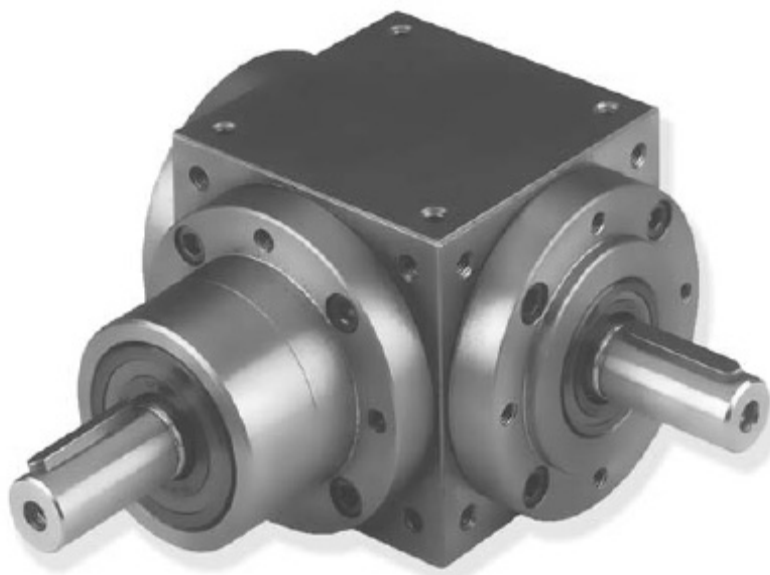

## 5.1 Технические характеристики

Данная серия ортогональных редукторов представляет собой жёсткую монолитную конструкцию, что позволяет использовать их при больших нагрузках.

Выпускается восемь типоразмеров данных редукторов с выходными валами трёх типов: с полым, цилиндрическими односторонним и двухсторонним. С противоположной от входного вала стороны может быть установлен второй выходной вал.

Данные редукторы могут поставляться в различных исполнениях, различных размеров, различной мощности, с различным передаточным отношением. Они характеризуются бесшумностью при работе, а также могут эксплуатироваться при высоких скоростях.

Корпус редуктора изготавливается из чугуна марки G20 UNI5007, и все его поверхности подвергаются механической обработке для облегчения монтажа. Единая смазочная камера позволяет гарантировать повышенную теплоотдачу и обеспечивает лучшую смазку всех внутренних деталей.

Механическая обработка корпуса осуществляется на современных многоцелевых станках с ЧПУ, которые обеспечивают получение максимальной точности изготовления.

Механизм данных редукторов состоит из двух конических геликоидальных шестерней GLEASON с точно шлифованным профилем, изготовленных из стали 16CrNi4 или 18NiCrMo5 UNI7846, подвергнутой поверхностному упрочнению и упрочнению закалкой.

## 5.2 Обозначение

Размер	Модели	ir	IEC (B5)	Выходной фланец	Дополнительный входной вал	Пример
Z	A-AS-AD-AP C-DR-B-BS BD-AH-BH AX-DX*	1-1.5-2-3-4-5		FC 1 FC 2 FC 3 FP 1 FP 2 FP 3	A 90-A 180-A 270 AS 90-AS 180-AS 270 AD 90-AD 180-AD 270 C 90 DR 90 AH 90-AH 180-AH 270 (не используется, если передаточное число $i_r = 1$ )	Z19 A 1.5 FC 1 A 90
	MA-MAS-MAD MC-MDR-MB MBS-MBD MAH-MBH	1-1.5-2-3-4-5	63 ... 160			Z19 MA 1.5 PAM 80 FC 1

\* Модели - мультипликаторы

Другие характеристики, которые должны быть специфицированы:

Положение клеммной коробки, если оно отличается от стандартного (1).

Монтажное положение с указанием заглушек для контроля уровня смазки и заправочных заглушек. Если данные положения не указаны, то стандартным считается положение M1.



### 5.3 Модели

Размеры: 12-19-24-32-38-42-55-75,  $i = 1-1.5-2-3-4-5$

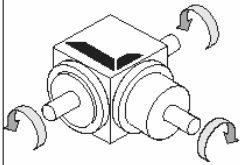

**A**

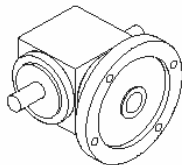

**MA**

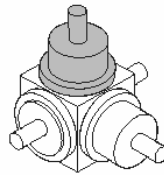

**A90**

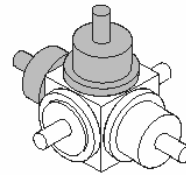

**A180**

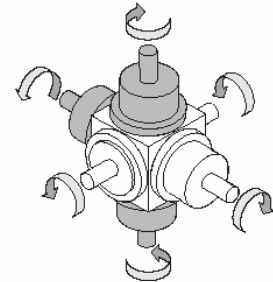

**A270**

Размеры: 12-19-24-32-38-42-55-75,  $i = 1-1.5-2-3-4-5$

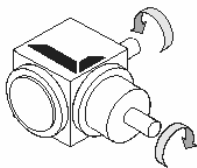

**AS**

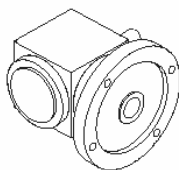

**MAS**

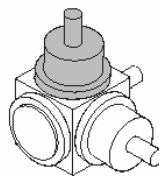

**AS90**

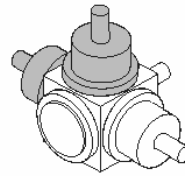

**AS180**

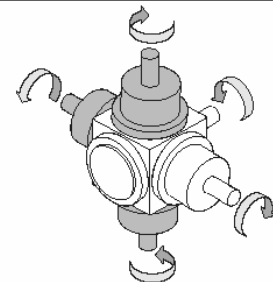

**AS270**

Размеры: 12-19-24-32-38-42-55-75,  $i = 1-1.5-2-3-4-5$

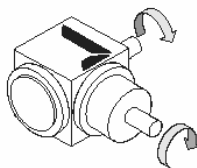

**AD**

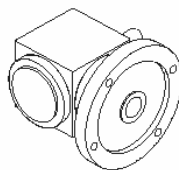

**MAD**

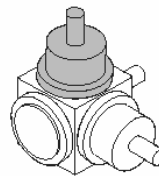

**AD90**

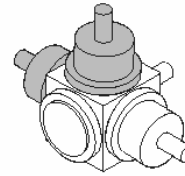

**AD180**

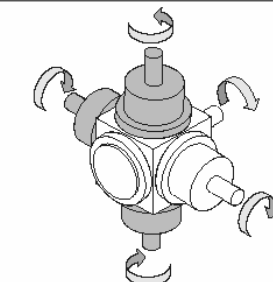

**AD270**

Размеры: 19-24-32-38-42-55-75,  $i = 1.5-2$   
 Модель повышающей передачи

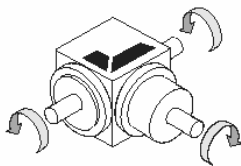

**AX**

Размеры: 12-19-24-32-38-42-55-75,  $i = 1-1.5-2-3-4-5$

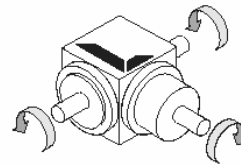

**AP**

Размеры: 12-19-24-32-38-42-55-75,  $i = 1-1.5-2-3-4-5$

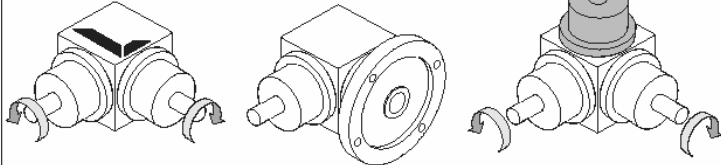

**C**

**MC**

**C90**

Размеры: 12-19-24-32-38-42-55-75,  $i = 1-1.5-2-3-4-5$   
 Два выходных вала

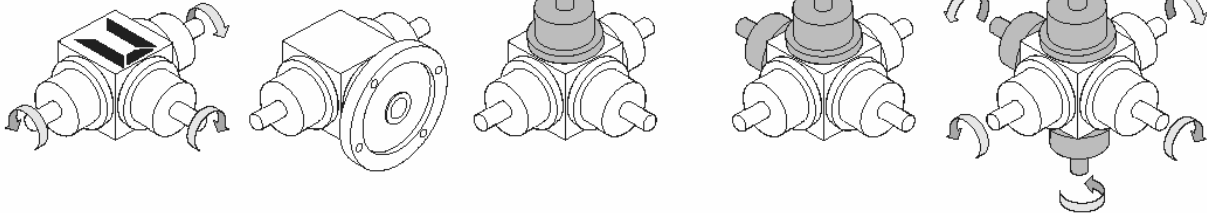

**DR**

**MDR**

**DR90**

**DR180**

**DR270**

Размеры: 12-19-24-32-38-42-55-75,  $i = 1-1.5-2-3-4-5$   
 Два выходных вала  
 Модель повышающей передачи

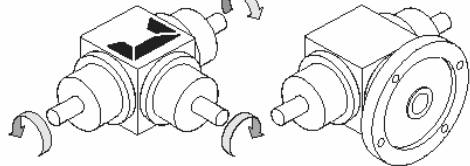

**DX**

**MDX**

Размеры: 12-19-24-32-38-42-55-75,  $i = 1-1.5-2-3-4-5$   
 Два входных вала

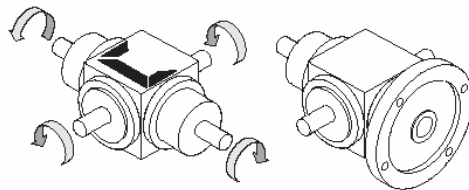

**B**

**MB**

Размеры: 12-19-24-32-38-42-55-75,  $i = 1-1.5-2-3-4-5$   
 Два входных вала

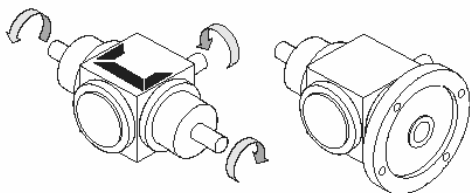

**BS**

**MBS**

Размеры: 12-19-24-32-38-42-55-75,  $i = 1-1.5-2-3-4-5$   
 Два входных вала

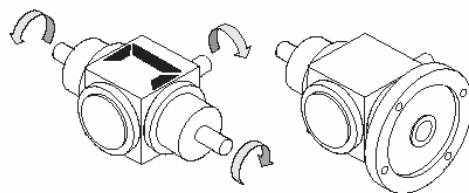

**BD**

**MBD**



Размеры: 12-19-24-32-38-42-55-75,  $i = 1-1.5-2-3-4-5$

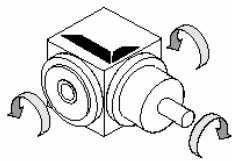

**AH**

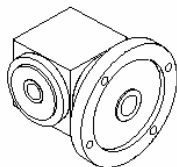

**MAH**

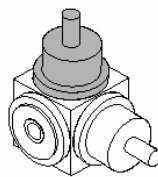

**AH90**

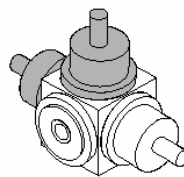

**AH180**

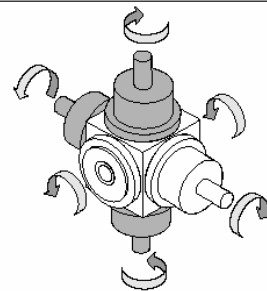

**AH270**

Размеры: 12-19-24-32-38-42-55-75,  $i = 1-1.5-2-3-4-5$   
Два входных вала

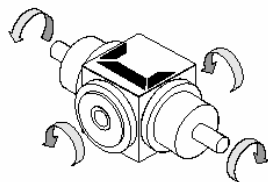

**BH**

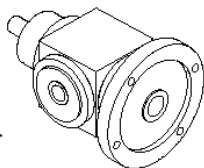

**MBH**

1- СТАНДАРТНОЕ

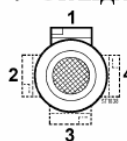

Положение клеммной коробки

### 5.4 Смазка

Ортогональные редукторы серии Z поставляются заправленными смазкой и снабжены заправочными, контрольными и сливными пробками.

При заказе необходимо указать монтажное положение. Иначе, редуктор будет поставлен с пробками, позиция которых характерна для положения M1.

### Монтажные положения и объём смазки (в литрах)

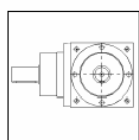

**M1**

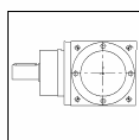

**M2**

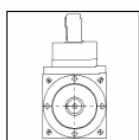

**M3**

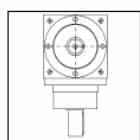

**M4**

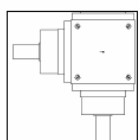

**M5**

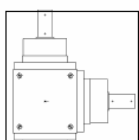

**M6**



Таблица 4.1

⚠ ZA							
12	19	24	32	38	42	55	75
0.1	0.15	0.22	0.60	1.1	2.2	3.6	9.0



Только для ZA.

Для получения более подробной информации обращайтесь в технический отдел нашей компании.

### 5.5 Радиальные и осевые нагрузки

Передачи, осуществляемые посредством звёздочек, зубчатых колес или шкивов, создают радиальную нагрузку ( $F_r$ ) на валы редуктора.

Значения радиальных и осевых нагрузок должны равняться или не должны превышать допустимых пределов, указанных в таблице.

#### Радиальные нагрузки

Таблица 5.2

i	$F_{r1}$ [N]							
	Z.							
	12	19	24	32	38	42	55	75
1-2-3	550	850	1400	2000	4000	6000	10000	25000
4-5	—	600	850	1400	2000	4000	6000	10000

i	$F_{r2}$ [N]							
	Z.							
	12	19	24	32	38	42	55	75
Все	900	1500	2200	3500	7000	10000	15000	35000

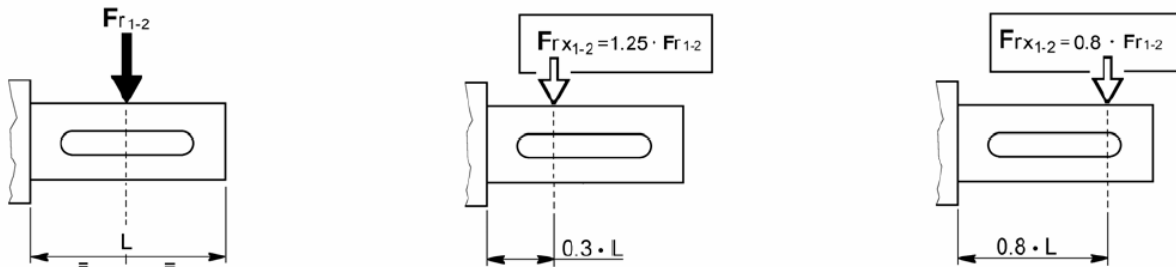

Радиальные нагрузки, указанные в таблице, приложены вертикально посередине стандартного выступающего конца вала и соответствуют редукторам, работающим с эксплуатационным коэффициентом, равным 1.

Величина нагрузки, прилагаемой не посередине выступающего конца выходного или входного вала, рассчитывается по следующей формуле:

на расстоянии 0,3 длины выступающего конца вала:

$$F_{rx} = 1.25 \times F_{r1-2}$$

на расстоянии 0,8 длины выступающего конца вала:

$$F_{rx} = 0.8 \times F_{r1-2}$$

#### Осевые нагрузки

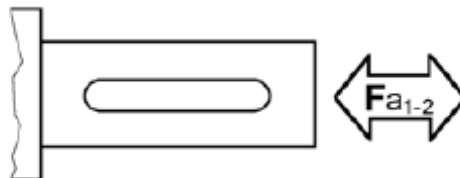



## Осевые нагрузки

Таблица 5.3

i	F <sub>a1</sub> [N]							
	Z.							
	12	19	24	32	38	42	55	75
На шарикоподшипниках (кроме модели AP)								
1-2-3	300	450	700	1100	1700	2700	5000	10000
4-5	—	400	450	700	1100	1700	2700	5000
На роликоподшипниках (модель AP)								
1-2-3	—	650	1000	1500	2400	4000	7800	16000
4-5	—	450	650	1000	1500	2400	4000	7800
i	F <sub>a2</sub> [N]							
	Z.							
	12	19	24	32	38	42	55	75
На шарикоподшипниках (кроме модели AP)								
Все	500	700	1300	1700	3400	4800	6800	15000
На роликоподшипниках (модель AP)								
Все	—	1000	1800	2500	5000	7000	10000	22000

### 5.6 Максимальный крутящий момент, передаваемый при последовательном соединении редукторов

При последовательном соединении нескольких ортогональных редукторов серии А и АН необходимо убедиться в том, что требуемый максимальный крутящий момент не превышает значение, указанное в таблице ниже.



Таблица 5.4

	Z.						
	19 A 19 АН	24 A 24 АН	32 A 32 АН	38 A 38 АН	42 A 42 АН	55 A 55 АН	75 A 75 АН
T <sub>2M</sub> max (Nm)	60	120	300	500	700	1600	4000

Если же рабочие условия являются более тяжелыми, чем упомянутые выше, то следует использовать ортогональные редукторы серии AP со сквозным валом большего диаметра.

Максимальный передаваемый крутящий момент в этом случае равен:

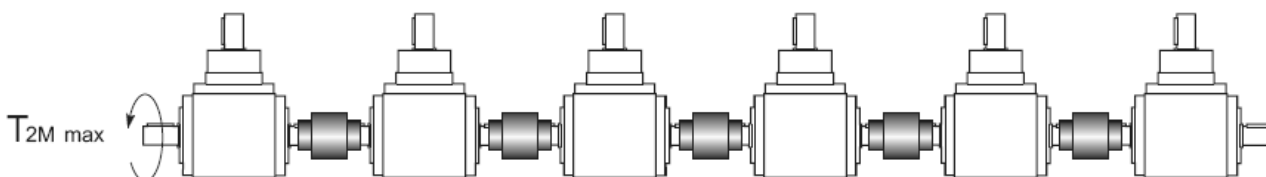
Таблица 5.5

	Z.						
	19 AP	24 AP	32 AP	38 AP	42 AP	55 AP	75 AP
T <sub>2M</sub> max (Nm)	120	300	500	700	1000	3000	6500

**5.7 Эксплуатационные показатели редукторов серии Z**
**Z 12 (A-AS-AD-AP-C-DR-B-BD-BS)**

2.5

ir	$n_1 = 2800 \text{ мин.}^{-1}$				$n_1 = 1400 \text{ мин.}^{-1}$				$n_1 = 900 \text{ мин.}^{-1}$				$n_1 = 500 \text{ мин.}^{-1}$				IEC
	$n_2$ мин. <sup>-1</sup>	$T_{2M}$ Нм	$P$ кВт	RD %	$n_2$ мин. <sup>-1</sup>	$T_{2M}$ Нм	$P$ кВт	RD %	$n_2$ мин. <sup>-1</sup>	$T_{2M}$ Нм	$P$ кВт	RD %	$n_2$ мин. <sup>-1</sup>	$T_{2M}$ Нм	$P$ кВт	RD %	
1	2800	13.1	4.0	95	1400	14.9	2.3	95	900	16.2	1.6	95	500	18.7	1.0	95	71 (B14) 63 (B5)
1.5	—	—	—	—	—	—	—	—	—	—	—	—	—	—	—	—	
2	1400	13.7	2.1	95	700	14.9	1.1	95	450	16.2	0.80	95	250	18.7	0.52	95	—
3	933	7.5	0.77	95	467	8.9	0.46	95	300	9.7	0.32	95	167	11.1	0.20	95	
4	—	—	—	—	—	—	—	—	—	—	—	—	—	—	—	—	—
5	—	—	—	—	—	—	—	—	—	—	—	—	—	—	—	—	—

**Z 12 Модель повышающей передачи (DX)**

2.5

ir	$n_1 = 1400 \text{ мин.}^{-1}$				$n_1 = 900 \text{ мин.}^{-1}$				$n_1 = 500 \text{ мин.}^{-1}$				IEC	
	$n_2$ мин. <sup>-1</sup>	$T_{2M}$ Нм	$P$ кВт	RD %	$n_2$ мин. <sup>-1</sup>	$T_{2M}$ Нм	$P$ кВт	RD %	$n_2$ мин. <sup>-1</sup>	$T_{2M}$ Нм	$P$ кВт	RD %		
1.5	—	—	—	—	—	—	—	—	—	—	—	—	—	—
2	2800	7.5	2.3	95	1800	8.1	1.6	95	1000	9.4	1.0	95		

**Z 19 (A-AS-AD-AP-C-DR-B-BD-BS-AH-BH)**

6.0

ir	$n_1 = 2800 \text{ мин.}^{-1}$				$n_1 = 1400 \text{ мин.}^{-1}$				$n_1 = 900 \text{ мин.}^{-1}$				$n_1 = 500 \text{ мин.}^{-1}$				IEC
	$n_2$ мин. <sup>-1</sup>	$T_{2M}$ Нм	$P$ кВт	RD %	$n_2$ мин. <sup>-1</sup>	$T_{2M}$ Нм	$P$ кВт	RD %	$n_2$ мин. <sup>-1</sup>	$T_{2M}$ Нм	$P$ кВт	RD %	$n_2$ мин. <sup>-1</sup>	$T_{2M}$ Нм	$P$ кВт	RD %	
1	2800	69	21	95	1400	73	11.3	95	900	75	7.4	95	500	76	4.2	95	71 (B5) 63 (B5)
1.5	1867	47	9.7	95	933	49	5.0	95	600	50	3.3	95	333	51	1.9	95	
2	1400	55	8.5	95	700	57	4.4	95	450	59	2.9	95	250	60	1.7	95	—
3	933	31	3.2	95	467	32	1.6	95	300	32	1.1	95	167	33	0.61	95	
4	700	35	2.7	95	350	28	1.1	95	225	28	0.7	95	125	29	0.40	95	—
5	560	28	1.7	95	280	29	0.90	95	180	29	0.6	95	100	30	0.33	95	—

**Z 19 Модель повышающей передачи (AX-DX)**

6.0

ir	$n_1 = 1400 \text{ мин.}^{-1}$				$n_1 = 900 \text{ мин.}^{-1}$				$n_1 = 500 \text{ мин.}^{-1}$				IEC
	$n_2$ мин. <sup>-1</sup>	$T_{2M}$ Нм	$P$ кВт	RD %	$n_2$ мин. <sup>-1</sup>	$T_{2M}$ Нм	$P$ кВт	RD %	$n_2$ мин. <sup>-1</sup>	$T_{2M}$ Нм	$P$ кВт	RD %	
1.5	2100	25	5.7	95	1350	25	3.7	95	750	26	2.1	95	—
2	2800	29	8.8	95	1800	30	5.9	95	1000	30	3.3	95	

**Z 24 (A-AS-AD-AP-C-DR-B-BD-BS-AH-BH)**

12.0

ir	$n_1 = 2800 \text{ мин.}^{-1}$				$n_1 = 1400 \text{ мин.}^{-1}$				$n_1 = 900 \text{ мин.}^{-1}$				$n_1 = 500 \text{ мин.}^{-1}$				IEC
	$n_2$ мин. <sup>-1</sup>	$T_{2M}$ Нм	$P$ кВт	RD %	$n_2$ мин. <sup>-1</sup>	$T_{2M}$ Нм	$P$ кВт	RD %	$n_2$ мин. <sup>-1</sup>	$T_{2M}$ Нм	$P$ кВт	RD %	$n_2$ мин. <sup>-1</sup>	$T_{2M}$ Нм	$P$ кВт	RD %	
1	2800	76	23	95	1400	82	12.7	95	900	86	8.5	95	500	90	4.9	95	90 (B5) 80 (B5) 71 (B5)
1.5	1867	78	16.0	95	933	81	8.3	95	600	83	5.5	95	333	85	3.1	95	
2	1400	69	10.7	95	700	72	5.6	95	450	74	3.6	95	250	75	2.1	95	80 (B5) 71 (B5)
3	933	45	4.6	95	467	47	2.4	95	300	48	1.6	95	167	49	0.89	95	
4	700	66	5.1	95	350	69	2.6	95	225	70	1.7	95	125	71	1.0	95	—
5	560	57	3.5	95	280	61	1.9	95	180	62	1.2	95	100	64	0.71	95	—

**Z 24 Модель повышающей передачи (AX-DX)**

12.0

ir	$n_1 = 1400 \text{ мин.}^{-1}$				$n_1 = 900 \text{ мин.}^{-1}$				$n_1 = 500 \text{ мин.}^{-1}$				IEC
	$n_2$ мин. <sup>-1</sup>	$T_{2M}$ Нм	$P$ кВт	RD %	$n_2$ мин. <sup>-1</sup>	$T_{2M}$ Нм	$P$ кВт	RD %	$n_2$ мин. <sup>-1</sup>	$T_{2M}$ Нм	$P$ кВт	RD %	
1.5	2100	40	9.4	95	1350	42	6.2	95	750	43	3.5	95	—
2	2800	36	11.2	95	1800	37	7.3	95	1000	38	4.1	95	



**Z 32 (A-AS-AD-AP-C-DR-B-BD-BS-AH-BH)**



22

ir	$n_1 = 2800 \text{ мин.}^{-1}$				$n_1 = 1400 \text{ мин.}^{-1}$				$n_1 = 900 \text{ мин.}^{-1}$				$n_1 = 500 \text{ мин.}^{-1}$				IEC
	$n_2$ мин. <sup>-1</sup>	$T_{2M}$ Нм	$P$ кВт	$RD$ %	$n_2$ мин. <sup>-1</sup>	$T_{2M}$ Нм	$P$ кВт	$RD$ %	$n_2$ мин. <sup>-1</sup>	$T_{2M}$ Нм	$P$ кВт	$RD$ %	$n_2$ мин. <sup>-1</sup>	$T_{2M}$ Нм	$P$ кВт	$RD$ %	
1	2800	173	54	95	1400	187	29	95	900	195	19.3	95	500	203	11.2	95	112 (B5) 100 (B5) 90 (B5) 80 (B5)
1.5	1867	150	31	95	933	163	16.7	95	600	159	10.5	95	333	178	6.5	95	
2	1400	132	20	95	700	140	10.8	95	450	142	7.1	95	250	147	4.1	95	
3	933	94	9.6	95	467	105	5.4	95	300	107	3.5	95	167	111	2.0	95	
4	700	92	7.1	95	350	100	3.9	95	225	101	2.5	95	125	104	1.4	95	
5	560	75	4.6	95	280	80	2.5	95	180	81	1.6	95	100	84	0.93	95	90 (B5) 80 (B5)

**Z 32 Модель повышающей передачи (AX-DX)**



22

ir	$n_1 = 1400 \text{ мин.}^{-1}$				$n_1 = 900 \text{ мин.}^{-1}$				$n_1 = 500 \text{ мин.}^{-1}$				IEC
	$n_2$ мин. <sup>-1</sup>	$T_{2M}$ Нм	$P$ кВт	$RD$ %	$n_2$ мин. <sup>-1</sup>	$T_{2M}$ Нм	$P$ кВт	$RD$ %	$n_2$ мин. <sup>-1</sup>	$T_{2M}$ Нм	$P$ кВт	$RD$ %	
1.5	2100	81	18.8	95	1350	80	11.9	95	750	89	7.3	95	—
2	2800	70	22	95	1800	71	14.1	95	1000	74	8.1	95	

**Z 38 (A-AS-AD-AP-C-DR-B-BD-BS-AH-BH)**



37

ir	$n_1 = 2800 \text{ мин.}^{-1}$				$n_1 = 1400 \text{ мин.}^{-1}$				$n_1 = 900 \text{ мин.}^{-1}$				$n_1 = 500 \text{ мин.}^{-1}$				IEC
	$n_2$ мин. <sup>-1</sup>	$T_{2M}$ Нм	$P$ кВт	$RD$ %	$n_2$ мин. <sup>-1</sup>	$T_{2M}$ Нм	$P$ кВт	$RD$ %	$n_2$ мин. <sup>-1</sup>	$T_{2M}$ Нм	$P$ кВт	$RD$ %	$n_2$ мин. <sup>-1</sup>	$T_{2M}$ Нм	$P$ кВт	$RD$ %	
1	2800	371	115	95	1400	393	61	95	900	403	40	95	500	420	23	95	132 (B5) 112 (B5) 100 (B5) 90 (B5)
1.5	1867	356	73	95	933	374	39	95	600	382	25	95	333	397	14.6	95	
2	1400	255	39	95	700	268	21	95	450	476	13.7	95	250	283	7.8	95	
3	933	192	19.8	95	467	200	10.3	95	300	205	6.8	95	167	211	3.9	95	
4	700	209	16.1	95	350	217	8.4	95	225	221	5.5	95	125	226	3.1	95	
5	560	211	13.0	95	280	219	6.8	95	180	222	4.4	95	100	228	2.5	95	112/100 (B5) 90 (B5)

**Z 38 Модель повышающей передачи (AX-DX)**



37

ir	$n_1 = 1400 \text{ мин.}^{-1}$				$n_1 = 900 \text{ мин.}^{-1}$				$n_1 = 500 \text{ мин.}^{-1}$				IEC
	$n_2$ мин. <sup>-1</sup>	$T_{2M}$ Нм	$P$ кВт	$RD$ %	$n_2$ мин. <sup>-1</sup>	$T_{2M}$ Нм	$P$ кВт	$RD$ %	$n_2$ мин. <sup>-1</sup>	$T_{2M}$ Нм	$P$ кВт	$RD$ %	
1.5	2100	187	43	95	1350	191	28	95	750	198	16.4	95	—
2	2800	134	41	95	1800	138	27	95	1000	142	15.6	95	

**Z 42 (A-AS-AD-AP-C-DR-B-BD-BS-AH-BH)**



57

ir	$n_1 = 2800 \text{ мин.}^{-1}$				$n_1 = 1400 \text{ мин.}^{-1}$				$n_1 = 900 \text{ мин.}^{-1}$				$n_1 = 500 \text{ мин.}^{-1}$				IEC
	$n_2$ мин. <sup>-1</sup>	$T_{2M}$ Нм	$P$ кВт	$RD$ %	$n_2$ мин. <sup>-1</sup>	$T_{2M}$ Нм	$P$ кВт	$RD$ %	$n_2$ мин. <sup>-1</sup>	$T_{2M}$ Нм	$P$ кВт	$RD$ %	$n_2$ мин. <sup>-1</sup>	$T_{2M}$ Нм	$P$ кВт	$RD$ %	
1	2800	437	135	95	1400	461	71	95	900	474	47	95	500	494	27	95	160 (B5) 132 (B5) 112 (B5)
1.5	1867	339	70	95	933	421	43	95	600	434	29	95	333	447	16.4	95	
2	1400	299	46	95	700	316	24	95	450	324	16.1	95	250	334	9.2	95	
3	933	228	23	95	467	235	12.1	95	300	242	8.0	95	167	248	4.6	95	
4	700	234	18.1	95	350	243	9.4	95	225	248	6.2	95	125	254	3.5	95	
5	560	211	13.0	95	280	219	6.8	95	180	220	4.4	95	100	228	2.5	95	132/112 (B5) 112 (B5)

**Z 42 Модель повышающей передачи (AX-DX)**



57

ir	$n_1 = 1400 \text{ мин.}^{-1}$				$n_1 = 900 \text{ мин.}^{-1}$				$n_1 = 500 \text{ мин.}^{-1}$				IEC
	$n_2$ мин. <sup>-1</sup>	$T_{2M}$ Нм	$P$ кВт	$RD$ %	$n_2$ мин. <sup>-1</sup>	$T_{2M}$ Нм	$P$ кВт	$RD$ %	$n_2$ мин. <sup>-1</sup>	$T_{2M}$ Нм	$P$ кВт	$RD$ %	
1.5	2100	211	49	95	1350	217	32	95	750	224	18.5	95	—
2	2800	158	49	95	1800	162	32	95	1000	167	18.4	95	



**Z 55 (A-AS-AD-AP-C-DR-B-BD-BS-AH-BH)**

87

ir	n <sub>1</sub> = 2800 мин. <sup>-1</sup>				n <sub>1</sub> = 1400 мин. <sup>-1</sup>				n <sub>1</sub> = 900 мин. <sup>-1</sup>				n <sub>1</sub> = 500 мин. <sup>-1</sup>				IEC
	n <sub>2</sub> мин. <sup>-1</sup>	T <sub>2M</sub> Нм	P кВт	RD %	n <sub>2</sub> мин. <sup>-1</sup>	T <sub>2M</sub> Нм	P кВт	RD %	n <sub>2</sub> мин. <sup>-1</sup>	T <sub>2M</sub> Нм	P кВт	RD %	n <sub>2</sub> мин. <sup>-1</sup>	T <sub>2M</sub> Нм	P кВт	RD %	
1	—	—	—	—	1400	992	153	95	900	1023	101	95	500	1053	58	95	160 (B5) 132 (B5) 112 (B5)
1.5	—	—	—	—	933	1057	109	95	600	1086	72	95	333	1123	41	95	
2	—	—	—	—	700	706	54	95	450	729	36	95	250	749	21	95	
3	—	—	—	—	467	481	25	95	300	497	16.4	95	167	508	9.3	95	
4	—	—	—	—	350	621	24	95	225	636	15.8	95	125	651	9.0	95	
5	—	—	—	—	280	595	18.4	95	180	607	12.0	95	100	621	6.8	95	132 (B5) 112 (B5)

**Z 55 Модель повышающей передачи (AX-DX)**

87

ir	n <sub>1</sub> = 1400 мин. <sup>-1</sup>				n <sub>1</sub> = 900 мин. <sup>-1</sup>				n <sub>1</sub> = 500 мин. <sup>-1</sup>				IEC
	n <sub>2</sub> мин. <sup>-1</sup>	T <sub>2M</sub> Нм	P кВт	RD %	n <sub>2</sub> мин. <sup>-1</sup>	T <sub>2M</sub> Нм	P кВт	RD %	n <sub>2</sub> мин. <sup>-1</sup>	T <sub>2M</sub> Нм	P кВт	RD %	
1.5	2100	529	122	95	1350	543	81	95	750	562	46	95	—
2	2800	353	109	95	1800	365	72	95	1000	375	41	95	

**Z 75 (A-AS-AD-AP-C-DR-B-BD-BS-AH-BH)**

255

ir	n <sub>1</sub> = 2800 мин. <sup>-1</sup>				n <sub>1</sub> = 1400 мин. <sup>-1</sup>				n <sub>1</sub> = 900 мин. <sup>-1</sup>				n <sub>1</sub> = 500 мин. <sup>-1</sup>				IEC
	n <sub>2</sub> мин. <sup>-1</sup>	T <sub>2M</sub> Нм	P кВт	RD %	n <sub>2</sub> мин. <sup>-1</sup>	T <sub>2M</sub> Нм	P кВт	RD %	n <sub>2</sub> мин. <sup>-1</sup>	T <sub>2M</sub> Нм	P кВт	RD %	n <sub>2</sub> мин. <sup>-1</sup>	T <sub>2M</sub> Нм	P кВт	RD %	
1	—	—	—	—	1400	2109	325	95	900	2202	218	95	500	2301	127	95	—
1.5	—	—	—	—	933	1754	180	95	600	1817	120	95	333	1888	69	95	
2	—	—	—	—	700	1723	133	95	450	1778	88	95	250	1841	51	95	
3	—	—	—	—	467	1772	91	95	300	1823	60	95	167	1881	35	95	
4	—	—	—	—	350	1466	57	95	225	1505	37	95	125	1547	21	95	
5	—	—	—	—	280	1278	39	95	180	1309	26	95	100	1342	14.8	95	

**Z 75 Модель повышающей передачи (AX-DX)**

255

ir	n <sub>1</sub> = 1400 мин. <sup>-1</sup>				n <sub>1</sub> = 900 мин. <sup>-1</sup>				n <sub>1</sub> = 500 мин. <sup>-1</sup>				IEC
	n <sub>2</sub> мин. <sup>-1</sup>	T <sub>2M</sub> Нм	P кВт	RD %	n <sub>2</sub> мин. <sup>-1</sup>	T <sub>2M</sub> Нм	P кВт	RD %	n <sub>2</sub> мин. <sup>-1</sup>	T <sub>2M</sub> Нм	P кВт	RD %	
1.5	2100	877	203	95	1350	909	135	95	750	944	78	95	—
2	2800	862	266	95	1800	889	176	95	1000	921	101	95	

Вес указан для базовой модели (версии А) с передаточным отношением ir = 1.



В таблице 4.6 указаны размеры двигателя IEC, а также возможные комбинации вал/фланец для присоединения двигателя к редуктору.

Таблица 4.6

Возможные варианты соединения с двигателями IEC							
	IEC	ir					
		1	1.5	2	3	4	5
Z 12	71	14/105 (B14)					
	63	11/140 (B5)					
Z 19	71	14/160 (B5)					
	63	11/140 (B5)					
Z 24	90	24/200 (B5)					
	80	19/200 (B5)					
	71	14/160 (B5)					
Z 32	100/112	28/250 (B5)					
	90	24/200 (B5)					
	80	19/200 (B5)					
Z 38	132	38/300 (B5)					
	100/112	28/250 (B5)					
	90	24/200 (B5)					
Z 42	160	42/350 (B5)					
	132	38/300 (B5)					
	100/112	28/250 (B5)					
Z 55	160	42/350 (B5)					
	132	38/300 (B5)					
	100/112	28/250 (B5)					

Пример расшифровки обозначений:

**11/140 (B5)**

**11/140:** стандартная комбинация вал/фланец  
**(B5)** : конструкция двигателя IEC

5.8 *Размеры*

**Z.A**

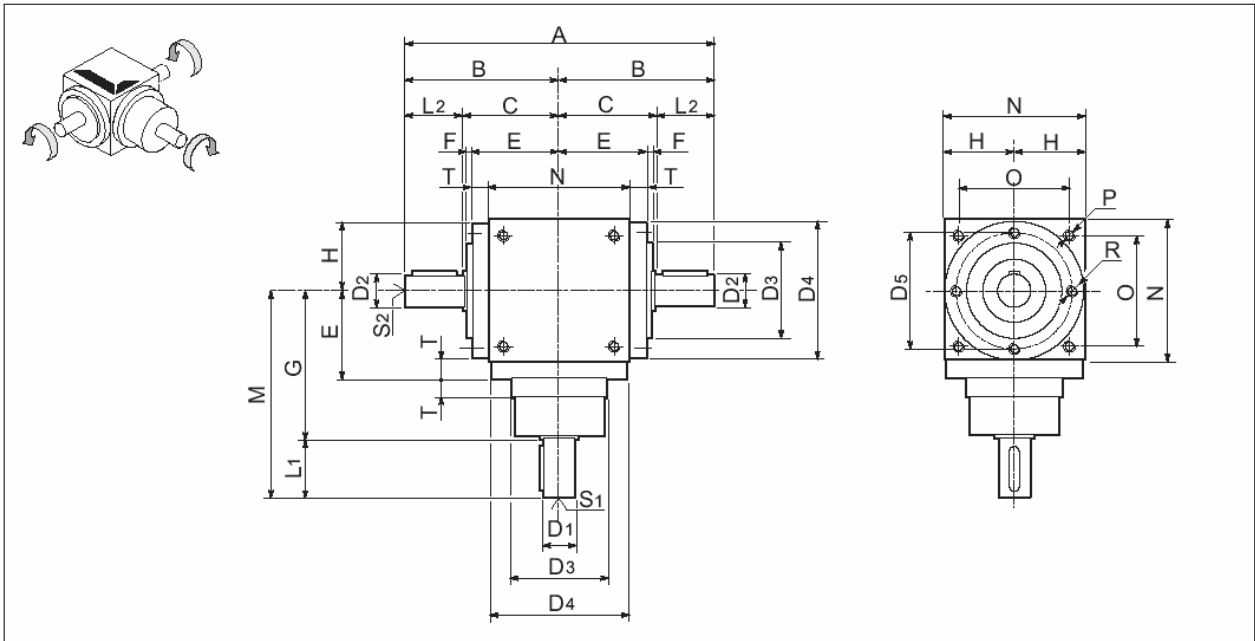

**Z.MA**

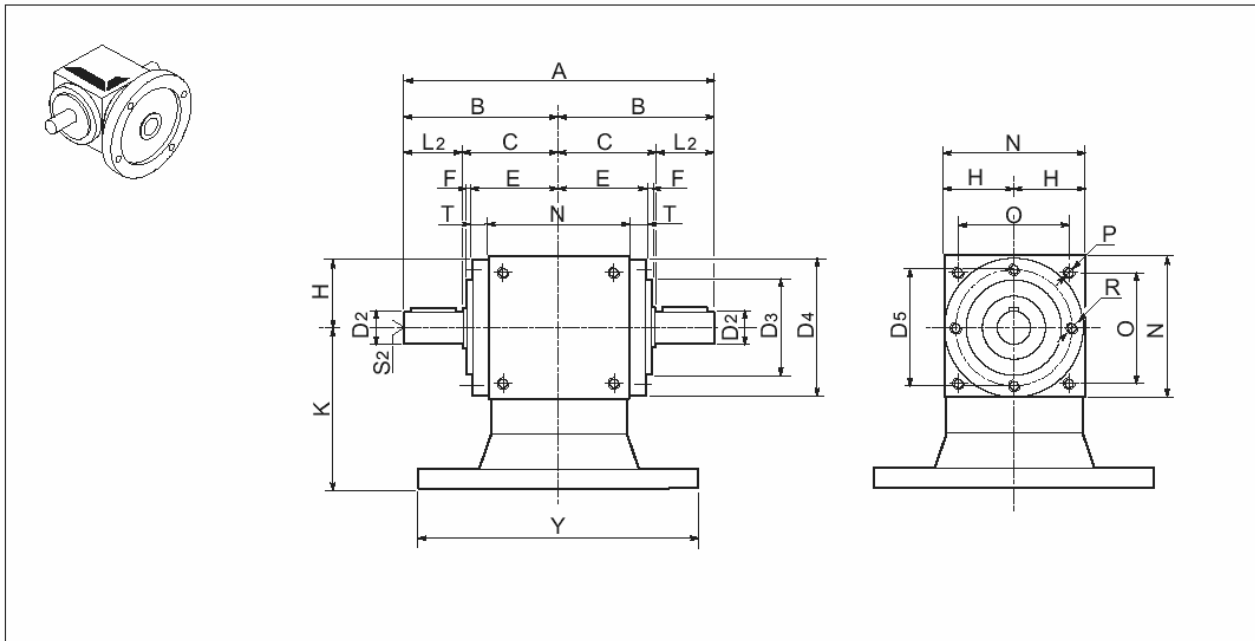



Z.A	C	D3 h8	D4	D5	E	F	G	H	N	O	P	R	T
12	46	44	-	54	42	2	74	32.5	65	45	M6	M6	-
19	65	60	86	72	59	4	100	45	90	70	M6	M6	14
24	80	70	105	88	73	5	115	55	110	88	M8	M8	18
32	95	95	135	115	88	5	145	70	140	110	M10	M10	18
38	110	120	165	145	103	5	170	85	170	136	M12	M12	18
42	125	135	190	165	118	5	195	100	200	155	M12	M12	18
55	150	170	230	205	143	5	245	120	240	190	M14	M14	23
75	225	-	300	-	195	-	350	165	330	248	M16	M16	30

Z.A	ir	A	B	M	Входной вал			Выходной вал		
					D1 j6	L1	S1	D2 j6	L2	S2
12	1-2-3	144	72	100	12	26	M4x8	12	26	M4x8
19	1-2-3	210	105	140	19	40	M6x12	19	40	M6x12
	130			14	30	M5x10				
24	1-2-3	260	130	165	24	50	M8x16	24	50	M8x16
	155			19	40	M6x12				
32	1-2-3	310	155	205	32	60	M10x20	32	60	M10x20
	195			24	50	M8x16				
38	1-2-3	360	180	240	38	70	M12x24	38	70	M12x24
	230			28	60	M10x20				
42	1-2-3	410	205	275	42	80	M12x24	42	80	M12x24
	255			32	60	M10x20				
55	1-2-3	520	260	355	55	110	M14x28	55	110	M14x28
	325			42	80	M12x24				
75	1-2-3	750	375	500	75	150	M16x32	75	150	M16x32
	460			55	110	M14x28				

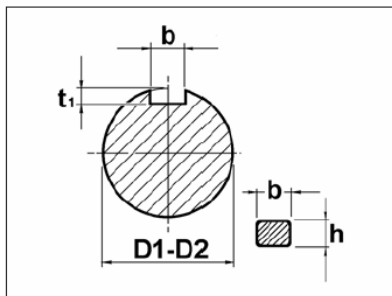

D1 - D2	b x h	t <sub>1</sub>
12	4 x 4	2.5
14	5 x 5	3.0
19	6 x 6	3.5
24	8 x 7	4.0
28	8 x 7	4.0
32	8 x 7	4.0
38	10 x 8	5.0
42	12 x 8	5.0
55	16 x 10	6.0
75	22 x 14	9.0

Z.MA	IEC	12		19		24		32		38		42		55	
		Y	K	Y	K	Y	K	Y	K	Y	K	Y	K	Y	K
	B5	105 (B14)	90	140	90	160	120	200	140	200	155	250	200	250	220
	140	90	160	90	200	120	250	140	250	155	300	200	300	220	
									300	155	350	200	350	220	

### Z.AS - Z.AD

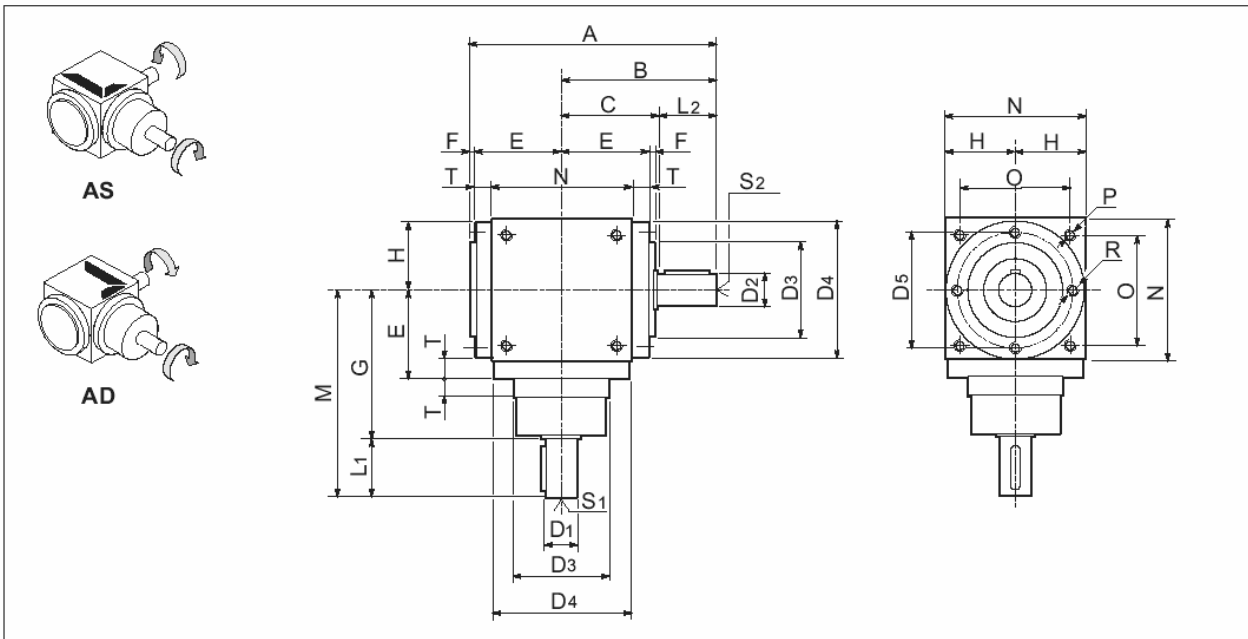

### Z.MAS - Z.MAD

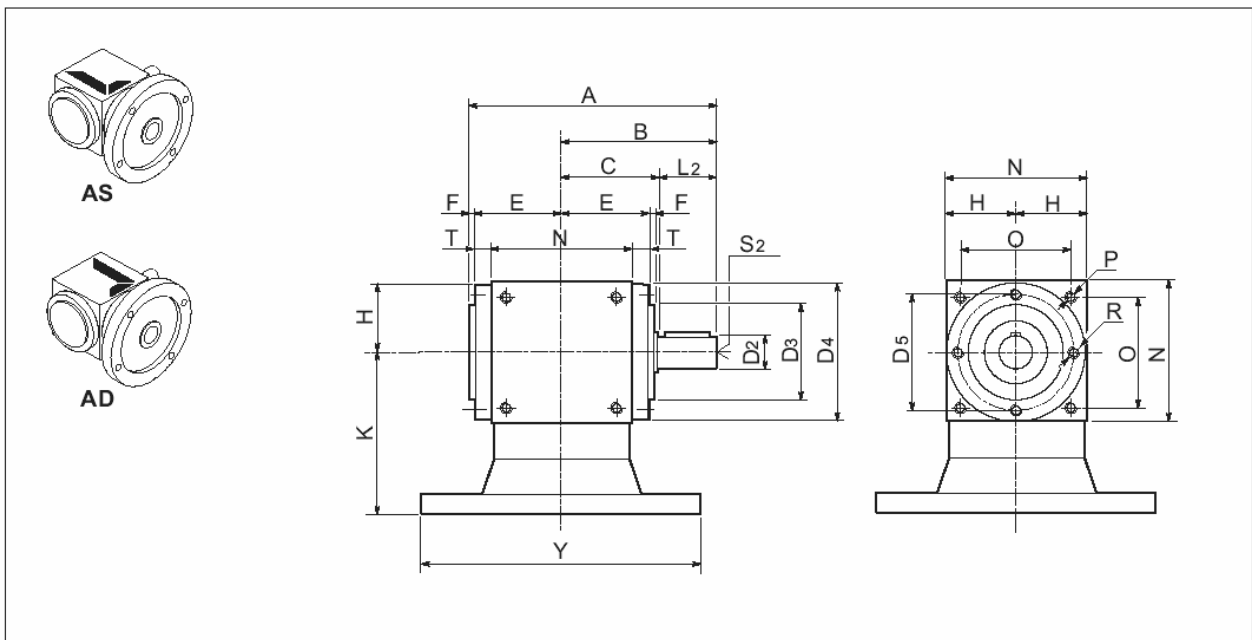



Z.AS Z.AD	C	D3 h8	D4	D5	E	F	G	H	N	O	P	R	T
12	46	44	-	54	42	2	74	32.5	65	45	M6	M6	-
19	65	60	86	72	59	4	100	45	90	70	M6	M6	14
24	80	70	105	88	73	5	115	55	110	88	M8	M8	18
32	95	95	135	115	88	5	145	70	140	110	M10	M10	18
38	110	120	165	145	103	5	170	85	170	136	M12	M12	18
42	125	135	190	165	118	5	195	100	200	155	M12	M12	18
55	150	170	230	205	143	5	245	120	240	190	M14	M14	23
75	225	-	300	-	195	-	350	165	330	248	M16	M16	30

Z.AS Z.AD	ir	A	B	M	Входной вал			Выходной вал		
					D1 j6	L1	S1	D2 j6	L2	S2
12	1-2-3	116	72	100	12	26	M4x8	12	26	M4x8
19	1-2-3	168	105	140	19	40	M6x12	19	40	M6x12
	4-5			130	14	30	M5x10			
24	1-2-3	208	130	165	24	50	M8x16	24	50	M8x16
	4-5			155	19	40	M6x12			
32	1-2-3	248	155	205	32	60	M10x20	32	60	M10x20
	4-5			195	24	50	M8x16			
38	1-2-3	288	180	240	38	70	M12x24	38	70	M12x24
	4-5			230	28	60	M10x20			
42	1-2-3	328	205	275	42	80	M12x24	42	80	M12x24
	4-5			255	32	60	M10x20			
55	1-2-3	408	260	355	55	110	M14x28	55	110	M14x28
	4-5			325	42	80	M12x24			
75	1-2-3	598	375	500	75	150	M16x32	75	150	M16x32
	4-5			460	55	110	M14x28			

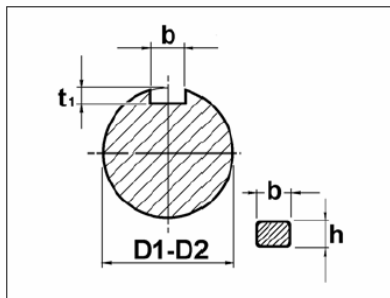

D1 - D2	b x h	t <sub>1</sub>
12	4 x 4	2.5
14	5 x 5	3.0
19	6 x 6	3.5
24	8 x 7	4.0
28	8 x 7	4.0
32	8 x 7	4.0
38	10 x 8	5.0
42	12 x 8	5.0
55	16 x 10	6.0
75	22 x 14	9.0

Z.MAS Z.MAD	IEC	12		19		24		32		38		42		55	
		Y	K	Y	K	Y	K	Y	K	Y	K	Y	K	Y	K
	B5	105 (B14)	90	140	90	160	120	200	140	200	155	250	200	250	220
	140	90	160	90	200	120	250	140	250	155	300	200	300	220	
									300	155	350	200	350	220	

### Z.AX

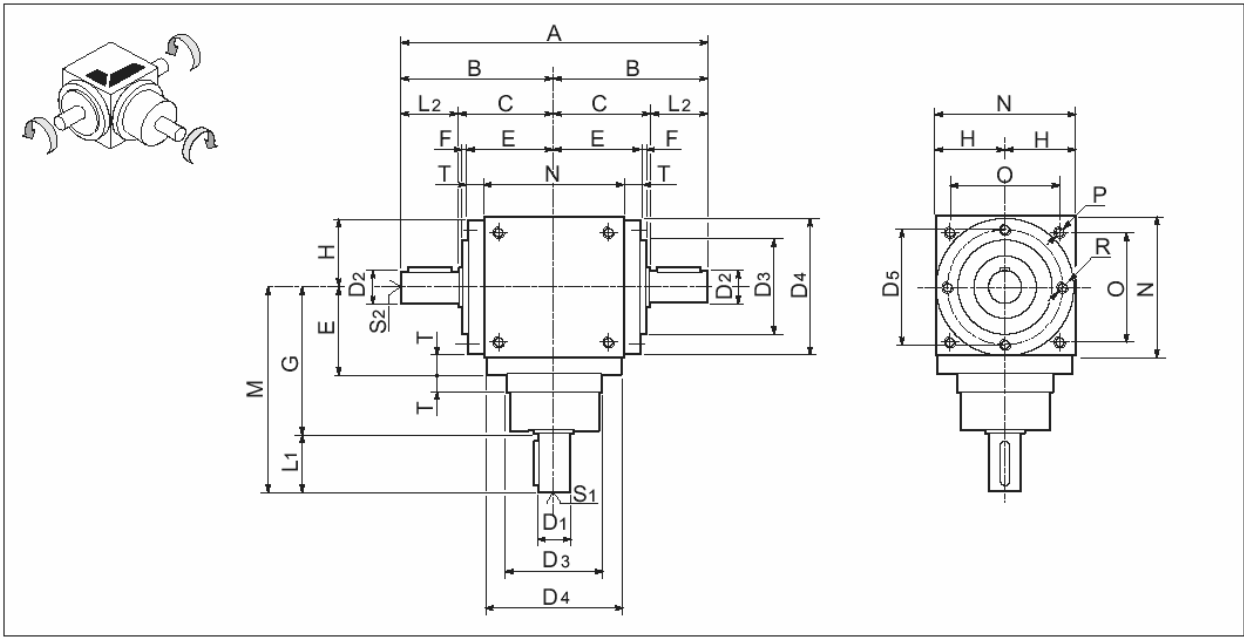



Z.AX	C	D3 h8	D4	D5	E	F	G	H	N	O	P	R	T
12	—	—	—	—	—	—	—	—	—	—	—	—	—
19	65	60	86	72	59	4	100	45	90	70	M6	M6	14
24	80	70	105	88	73	5	115	55	110	88	M8	M8	18
32	95	95	135	115	88	5	145	70	140	110	M10	M10	18
38	110	120	165	145	103	5	170	85	170	136	M12	M12	18
42	125	135	190	165	118	5	195	100	200	155	M12	M12	18
55	150	170	230	205	143	5	245	120	240	190	M14	M14	23
75	225	—	300	—	195	—	350	165	330	248	M16	M16	30

Z.AX	ir	A	B	M	Входной вал			Выходной вал		
					D1 j6	L1	S1	D2 j6	L2	S2
12	—	—	—	—	—	—	—	—	—	—
19	1.5	190	95	140	19	40	M6x12	14	30	M5x10
	2									
24	1.5	240	120	165	24	50	M8x16	19	40	M6x12
	2									
32	1.5	290	145	205	32	60	M10x20	24	50	M8x16
	2	270	135					19	40	M6x12
38	1.5	340	170	240	38	70	M12x24	28	60	M10x20
	2									
42	1.5	390	195	275	42	80	M12x24	38	70	M10x20
	2	370	185					32	60	
55	1.5	460	230	355	55	110	M14x28	42	80	M12x24
	2	440	220					38	70	M12x24
75	1.5	670	335	500	75	150	M16x32	55	110	M14x28
	2									

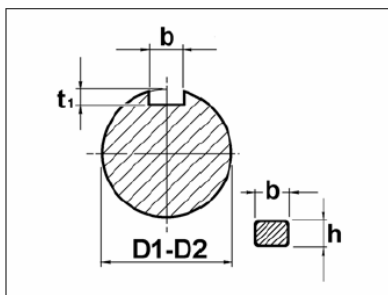

D1 - D2	b x h	t <sub>1</sub>
12	4 x 4	2.5
14	5 x 5	3.0
19	6 x 6	3.5
24	8 x 7	4.0
28	8 x 7	4.0
32	8 x 7	4.0
38	10 x 8	5.0
42	12 x 8	5.0
55	16 x 10	6.0
75	22 x 14	9.0



### Z.AP

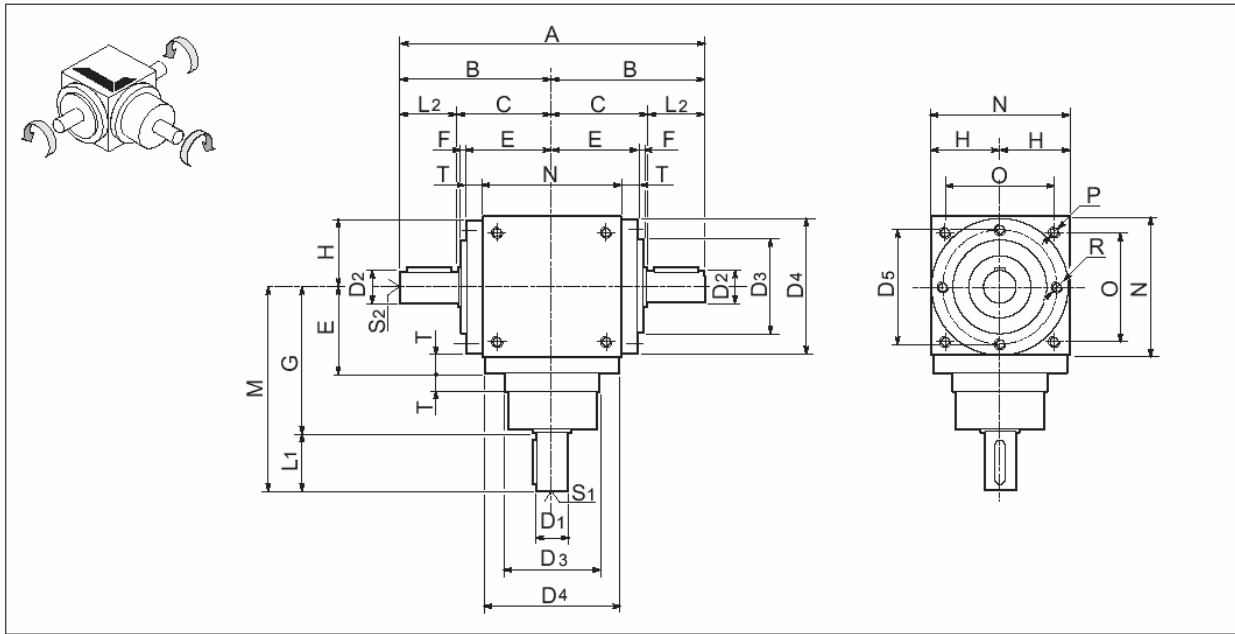



Z.AP	C	D3 h8	D4	D5	E	F	G	H	N	O	P	R	T
12	—	—	—	—	—	—	—	—	—	—	—	—	—
19	65	60	86	72	59	4	100	45	90	70	M6	M6	14
24	80	70	105	88	73	5	115	55	110	88	M8	M8	18
32	95	95	135	115	88	5	145	70	140	110	M10	M10	18
38	110	120	165	145	103	5	170	85	170	136	M12	M12	18
42	125	135	190	165	118	5	195	100	200	155	M12	M12	18
55	150	170	230	205	143	5	245	120	240	190	M14	M14	23
75	225	—	300	—	195	—	350	165	330	248	M16	M16	30

Z.AP	ir	A	B	M	Входной вал			Выходной вал			
					D1 j6	L1	S1	D2 j6	L2	S2	
12	1-2-3	—	—	—	—	—	—	—	—	—	—
19	1-2-3	230	115	140	19	40	M6x12	24	50	M8x16	
	130			14	30	M5x10					
24	1-2-3	280	140	165	24	50	M8x16	32	60	M10x20	
	155			19	40	M6x12					
32	1-2-3	330	165	205	32	60	M10x20	38	70	M12x24	
	195			24	50	M8x16					
38	1-2-3	380	190	240	38	70	M12x24	42	80	M12x24	
	230			28	60	M10x20					
42	1-2-3	430	215	275	42	80	M12x24	48	90	M14x28	
	255			32	60	M10x20					
55	1-2-3	520	260	355	55	110	M14x28	70	110	M14x28	
	325			42	80	M12x24					
75	1-2-3	750	375	500	75	150	M16x32	90	150	M16x32	
	460			55	110	M14x28					

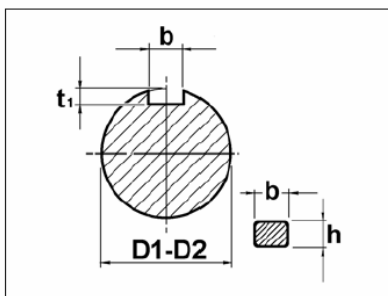

D1 - D2	b x h	t <sub>1</sub>
12	4 x 4	2.5
14	5 x 5	3.0
19	6 x 6	3.5
24	8 x 7	4.0
28	8 x 7	4.0
32	8 x 7	4.0
38	10 x 8	5.0
42	12 x 8	5.0
48	14 x 9	5.5
55	16 x 10	6.0
70	20 x 12	7.5
75	22 x 14	9.0
90	25 x 14	9.0

### Z.C

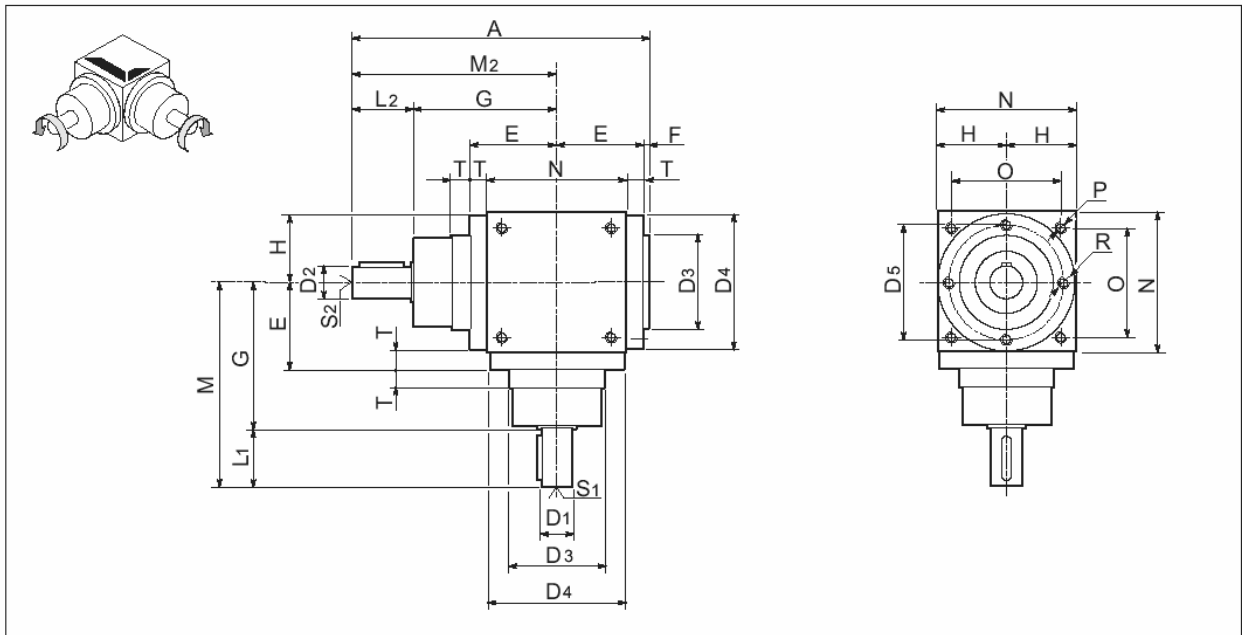

### Z.MC

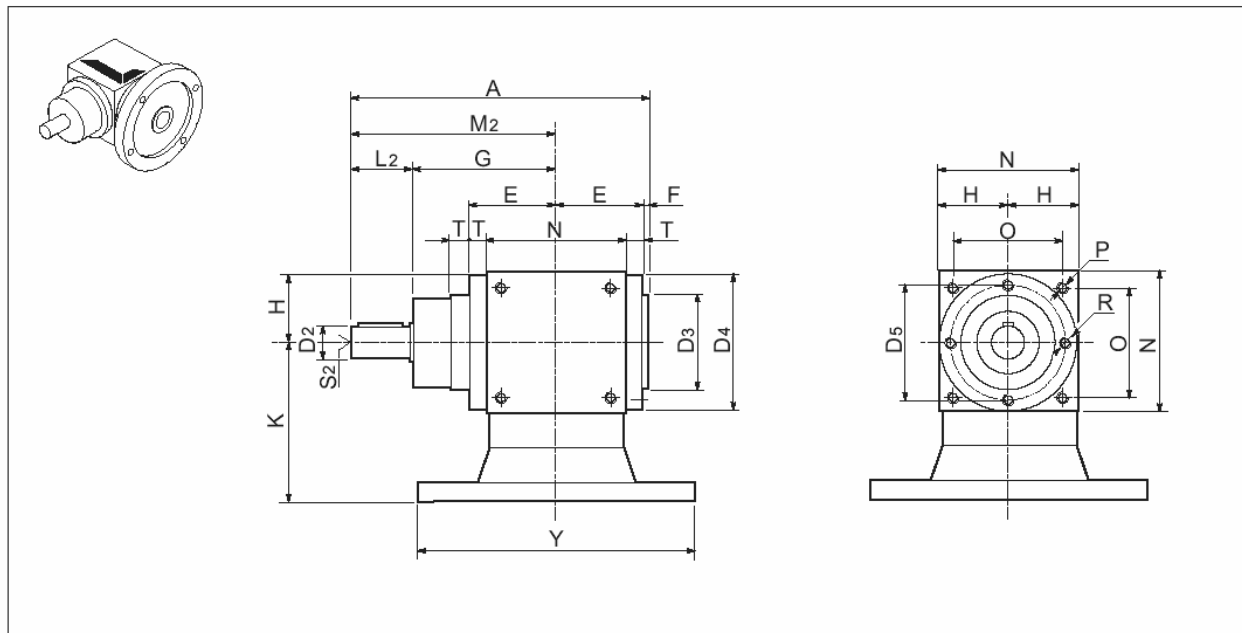



Z.C	D3 h8	D4	D5	E	F	G	H	N	O	P	R	T
12	44	-	54	42	2	74	32.5	65	45	M6	M6	-
19	60	86	72	59	4	100	45	90	70	M6	M6	14
24	70	105	88	73	5	115	55	110	88	M8	M8	18
32	95	135	115	88	5	145	70	140	110	M10	M10	18
38	120	165	145	103	5	170	85	170	136	M12	M12	18
42	135	190	165	118	5	195	100	200	155	M12	M12	18
55	170	230	205	143	5	245	120	240	190	M14	M14	23
75	-	300	-	195	-	350	165	330	248	M16	M16	30

Z.C	ir	A	M	M2	Входной вал			Выходной вал		
					D1 j6	L1	S1	D2 j6	L2	S2
12	1-2-3	144	100	100	12	26	M4x8	12	26	M4x8
19	1-2-3	203	140	140	19	40	M6x12	19	40	M6x12
	4-5		130		14	30	M5x10			
24	1-2-3	243	165	165	24	50	M8x16	24	50	M8x16
	4-5		155		19	40	M6x12			
32	1-2-3	298	205	205	32	60	M10x20	32	60	M10x20
	4-5		195		24	50	M8x16			
38	1-2-3	348	240	240	38	70	M12x24	38	70	M12x24
	4-5		230		28	60	M10x20			
42	1-2-3	398	275	275	42	80	M12x24	42	80	M12x24
	4-5		255		32	60	M10x20			
55	1-2-3	503	355	355	55	110	M14x28	55	110	M14x28
	4-5		325		42	80	M12x24			
75	1-2-3	723	500	500	75	150	M16x32	75	150	M16x32
	4-5		460		55	110	M14x28			

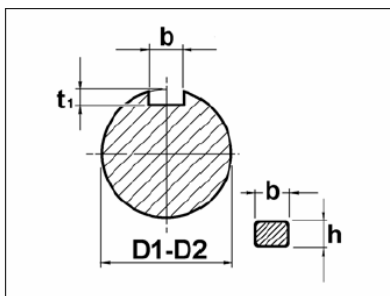

D1 - D2	b x h	t1
12	4 x 4	2.5
14	5 x 5	3.0
19	6 x 6	3.5
24	8 x 7	4.0
28	8 x 7	4.0
32	8 x 7	4.0
38	10 x 8	5.0
42	12 x 8	5.0
55	16 x 10	6.0
75	22 x 14	9.0

Z.MC	IEC	12		19		24		32		38		42		55	
		Y	K	Y	K	Y	K	Y	K	Y	K	Y	K	Y	K
	B5	105 (B14)	90	140	90	160	120	200	140	200	155	250	200	250	220
		140	90	160	90	200	120	250	140	250	155	300	200	300	220
										300	155	350	200	350	220

### Z.DR

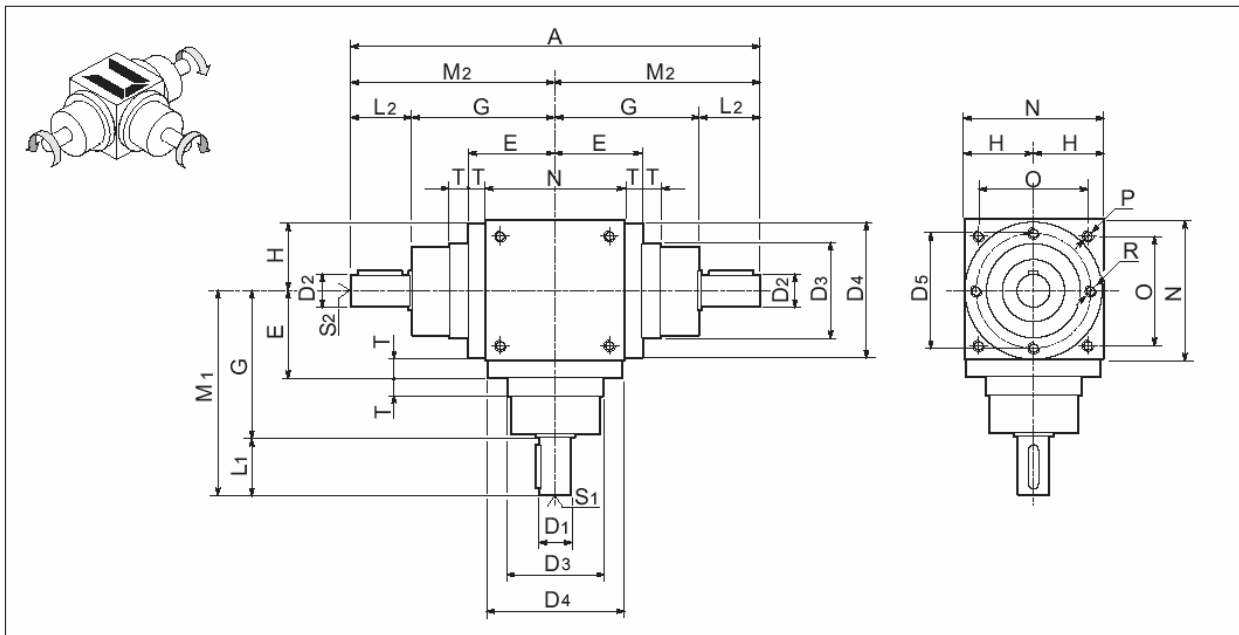

### Z.MDR

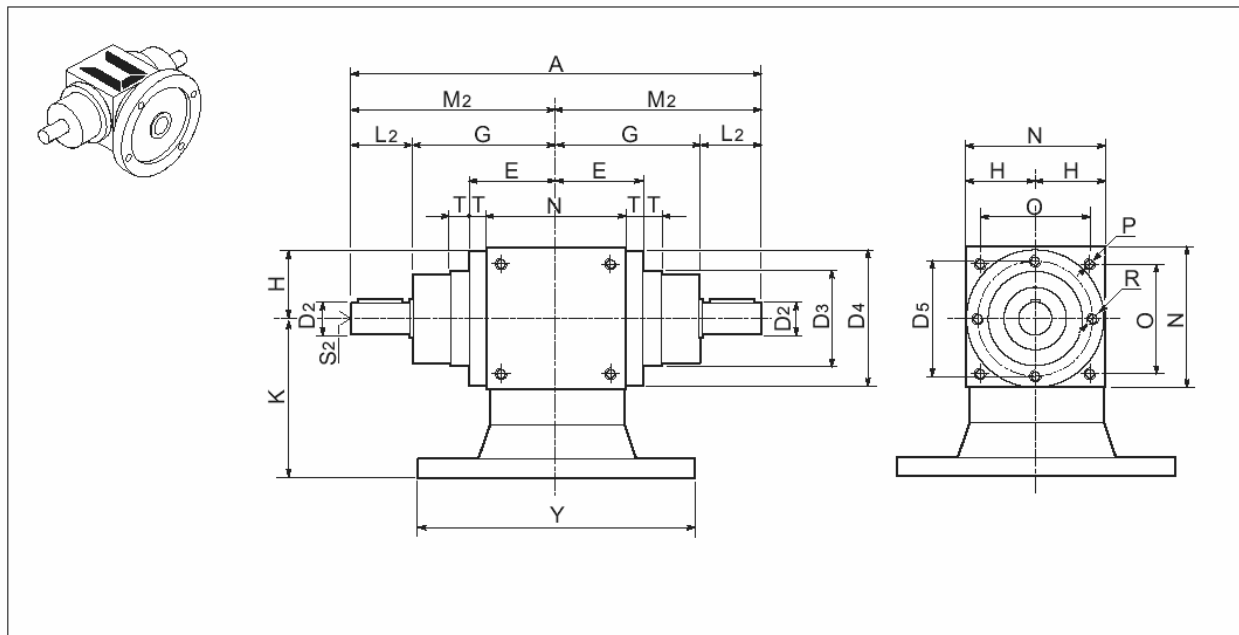



Z.DR	D3 h8	D4	D5	E	F	G	H	N	O	P	R	T
12	44	—	54	42	2	74	32.5	65	45	M6	M6	—
19	60	86	72	59	4	100	45	90	70	M6	M6	14
24	70	105	88	73	5	115	55	110	88	M8	M8	18
32	95	135	115	88	5	145	70	140	110	M10	M10	18
38	120	165	145	103	5	170	85	170	136	M12	M12	18
42	135	190	165	118	5	195	100	200	155	M12	M12	18
55	170	230	205	143	5	245	120	240	190	M14	M14	23
75	—	300	—	195	—	350	165	330	248	M16	M16	30

Z.DR	ir	A	M1	M2	Входной вал			Выходной вал		
					D1 j6	L1	S1	D2 j6	L2	S2
12	1-2-3	200	100	100	12	26	M4x8	12	26	M4x8
19	1-2-3	280	140	140	19	40	M6x12	19	40	M6x12
	4-5		130		14	30	M5x10			
24	1-2-3	330	165	165	24	50	M8x16	24	50	M8x16
	4-5		155		19	40	M6x12			
32	1-2-3	410	205	205	32	60	M10x20	32	60	M10x20
	4-5		195		24	50	M8x16			
38	1-2-3	480	240	240	38	70	M12x24	38	70	M12x24
	4-5		230		28	60	M10x20			
42	1-2-3	550	275	275	42	80	M12x24	42	80	M12x24
	4-5		255		32	60	M10x20			
55	1-2-3	710	355	355	55	110	M14x28	55	110	M14x28
	4-5		325		42	80	M12x24			
75	1-2-3	1000	500	500	75	150	M16x32	75	150	M16x32
	4-5		460		55	110	M14x28			

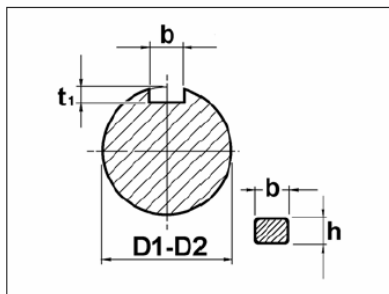

D1 - D2	b x h	t <sub>1</sub>
12	4 x 4	2.5
14	5 x 5	3.0
19	6 x 6	3.5
24	8 x 7	4.0
28	8 x 7	4.0
32	8 x 7	4.0
38	10 x 8	5.0
42	12 x 8	5.0
55	16 x 10	6.0
75	22 x 14	9.0

Z.MDR	IEC	12		19		24		32		38		42		55	
		Y	K	Y	K	Y	K	Y	K	Y	K	Y	K	Y	K
	B5	105 (B14)	90	140	90	160	120	200	140	200	155	250	200	250	220
		140	90	160	90	200	120	250	140	250	155	300	200	300	220
										300	155	350	200	350	220

### Z.DX

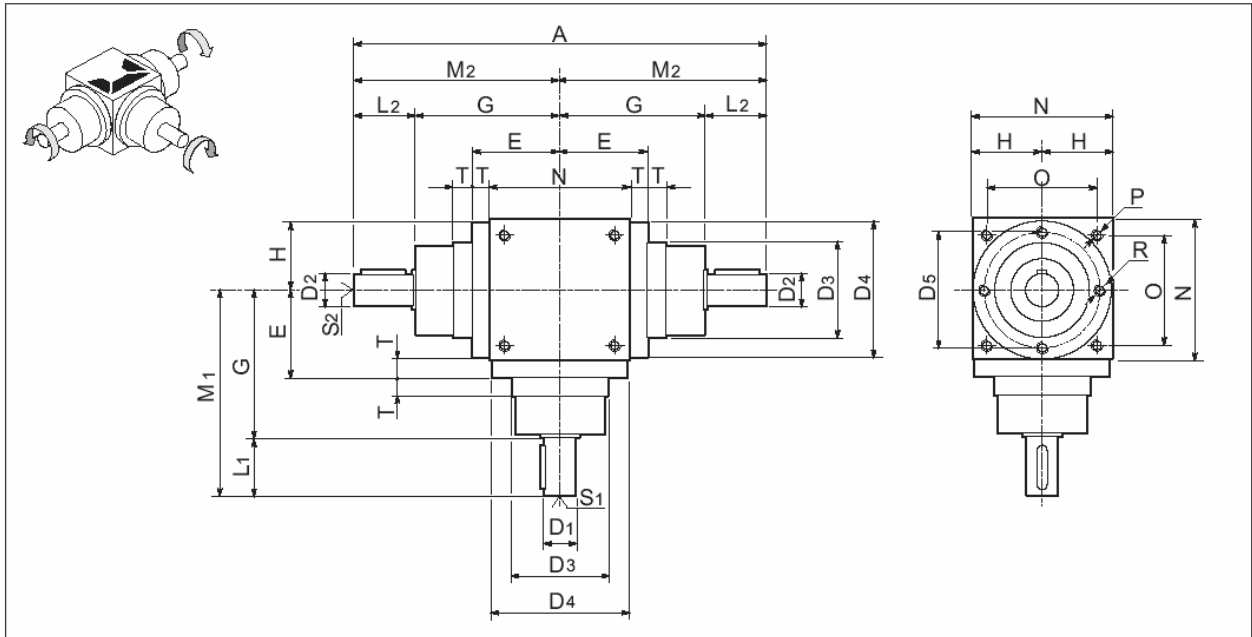

### Z.MDX

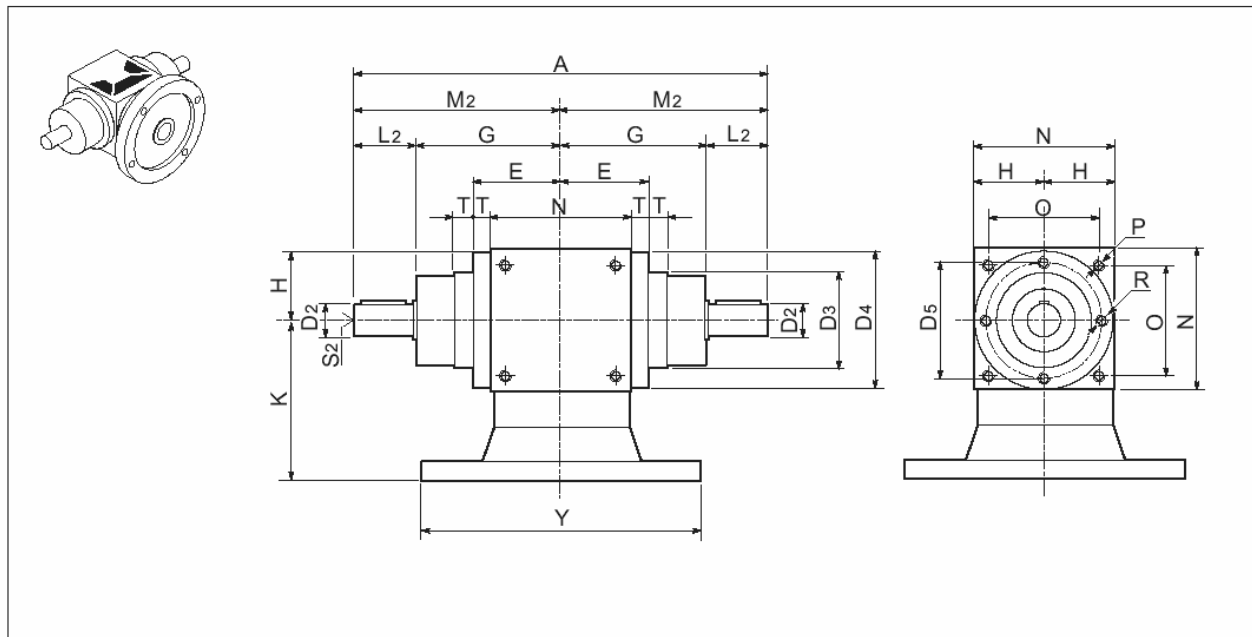



Z.DX	D3 h8	D4	D5	E	G	H	N	O	P	R	T
12	44	-	54	42	74	32.5	65	45	M6	M6	-
19	60	86	72	59	100	45	90	70	M6	M6	14
24	70	105	88	73	115	55	110	88	M8	M8	18
32	95	135	115	88	145	70	140	110	M10	M10	18
38	120	165	145	103	170	85	170	136	M12	M12	18
42	135	190	165	118	195	100	200	155	M12	M12	18
55	170	230	205	143	245	120	240	190	M14	M14	23
75	-	300	-	195	350	165	330	248	M16	M16	30

Z.DX	ir	A	M1	M2	Входной вал			Выходной вал		
					D1 j6	L1	S1	D2 j6	L2	S2
12	1-2-3	200	100	100	12	26	M4x8	12	26	M4x8
	4-5	280	140		19	40	M6x12			
19	1-2-3	330	165	165	14	30	M5x10	19	40	M6x12
	4-5	310	155		24	50	M8x16			
24	1-2-3	410	205	205	19	40	M6x12	24	50	M8x16
	4-5	390	195		32	60	M10x20			
32	1-2-3	480	240	240	24	50	M8x16	32	60	M10x20
	4-5	460	230		38	70	M12x24			
38	1-2-3	550	275	275	28	60	M10x20	38	70	M12x24
	4-5	510	255		42	80	M12x24			
42	1-2-3	710	355	355	32	60	M10x20	42	80	M12x24
	4-5	650	325		55	110	M14x28			
55	1-2-3	1000	500	500	42	80	M12x24	55	110	M14x28
	4-5	920	460		75	150	M16x32			
75	1-2-3				55	110	M14x28	75	150	M16x32
	4-5									

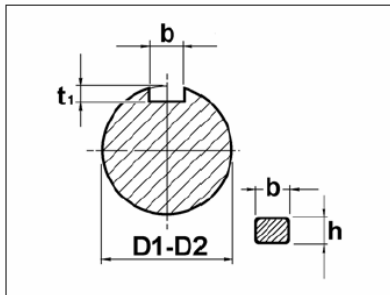

D1 - D2	b x h	t <sub>1</sub>
12	4 x 4	2.5
14	5 x 5	3.0
19	6 x 6	3.5
24	8 x 7	4.0
28	8 x 7	4.0
32	8 x 7	4.0
38	10 x 8	5.0
42	12 x 8	5.0
55	16 x 10	6.0
75	22 x 14	9.0

Z.MDX	IEC	12		19		24		32		38		42		55	
		Y	K	Y	K	Y	K	Y	K	Y	K	Y	K	Y	K
	B5	105 (B14)	90	140	90	160	120	200	140	200	155	250	200	250	220
		140	90	160	90	200	120	250	140	250	155	300	200	300	220
										300	155	350	200	350	220

### Z.B

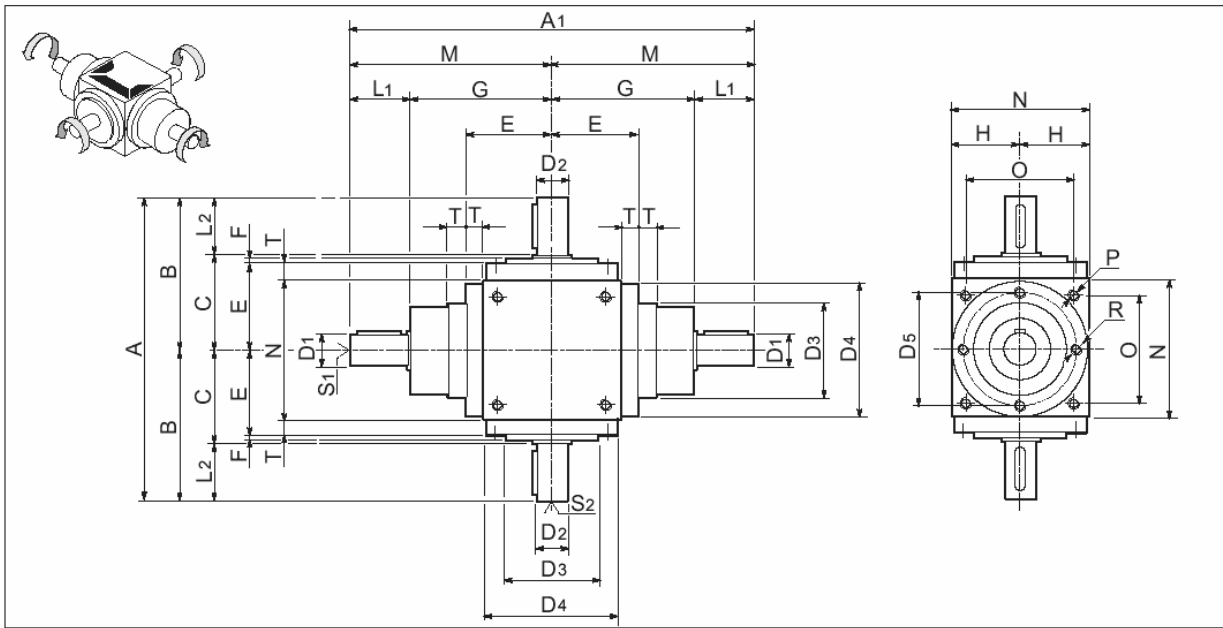

### Z.MB

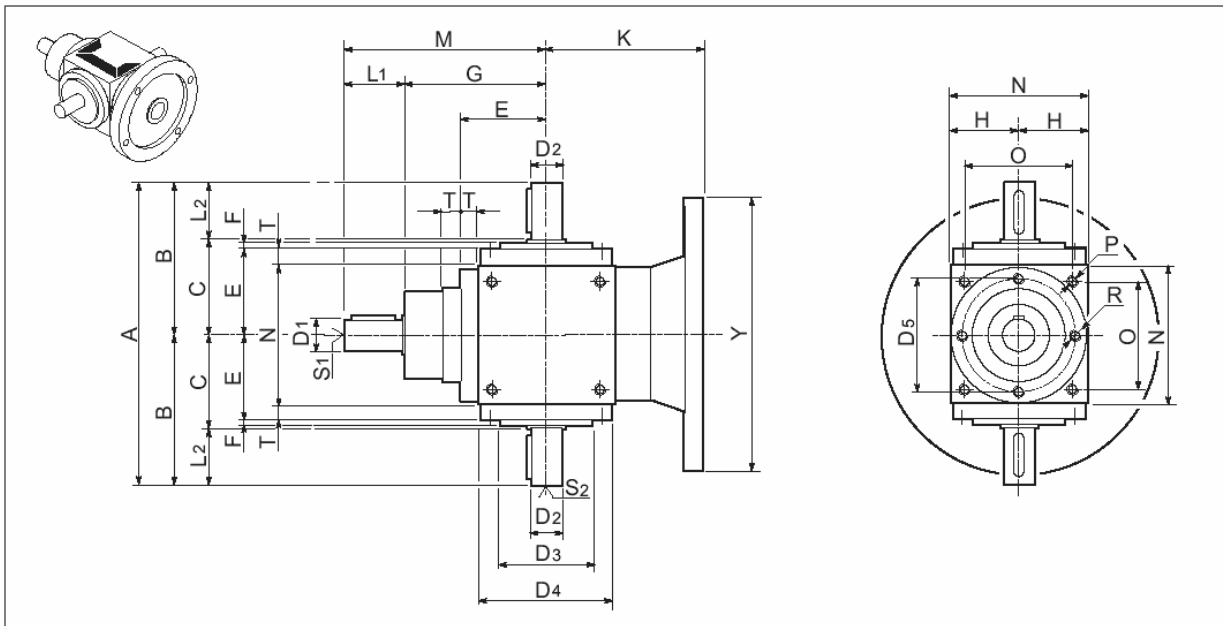



Z.B	C	D3 h8	D4	D5	E	F	G	H	N	O	P	R	T
12	46	44	—	54	42	2	74	32.5	65	45	M6	M6	—
19	65	60	86	72	59	4	100	45	90	70	M6	M6	14
24	80	70	105	88	73	5	115	55	110	88	M8	M8	18
32	95	95	135	115	88	5	145	70	140	110	M10	M10	18
38	110	120	165	145	103	5	170	85	170	136	M12	M12	18
42	125	135	190	165	118	5	195	100	200	155	M12	M12	18
55	150	170	230	205	143	5	245	120	240	190	M14	M14	23
75	225	—	300	—	195	—	350	165	330	248	M16	M16	30

Z.B	ir	A1	A2	B	M	Входной вал			Выходной вал		
						D1 j6	L1	S1	D2 j6	L2	S2
12	1-2-3	200	144	72	100	12	26	M4x8	12	26	M4x8
19	1-2-3	280	210	105	140	19	40	M6x12	19	40	M6x12
	4-5	260			130	14	30	M5x10			
24	1-2-3	330	260	130	165	24	50	M8x16	24	50	M8x16
	4-5	310			155	19	40	M6x12			
32	1-2-3	410	310	155	205	32	60	M10x20	32	60	M10x20
	4-5	390			195	24	50	M8x16			
38	1-2-3	480	360	180	240	38	70	M12x24	38	70	M12x24
	4-5	460			230	28	60	M10x20			
42	1-2-3	550	410	205	275	42	80	M12x24	42	80	M12x24
	4-5	510			255	32	60	M10x20			
55	1-2-3	710	520	260	355	55	110	M14x28	55	110	M14x28
	4-5	650			325	42	80	M12x24			
75	1-2-3	1000	750	375	500	75	150	M16x32	75	150	M16x32
	4-5	920			460	55	110	M14x28			

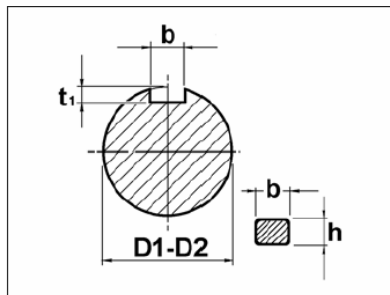

D1 - D2	b x h	t <sub>1</sub>
12	4 x 4	2.5
14	5 x 5	3.0
19	6 x 6	3.5
24	8 x 7	4.0
28	8 x 7	4.0
32	8 x 7	4.0
38	10 x 8	5.0
42	12 x 8	5.0
55	16 x 10	6.0
75	22 x 14	9.0

Z.MB	IEC	12		19		24		32		38		42		55	
		Y	K	Y	K	Y	K	Y	K	Y	K	Y	K	Y	K
	B5	105 (B14)	90	140	90	160	120	200	140	200	155	250	200	250	220
		140	90	160	90	200	120	250	140	250	155	300	200	300	220
										300	155	350	200	350	220

### Z.BS - Z.BD

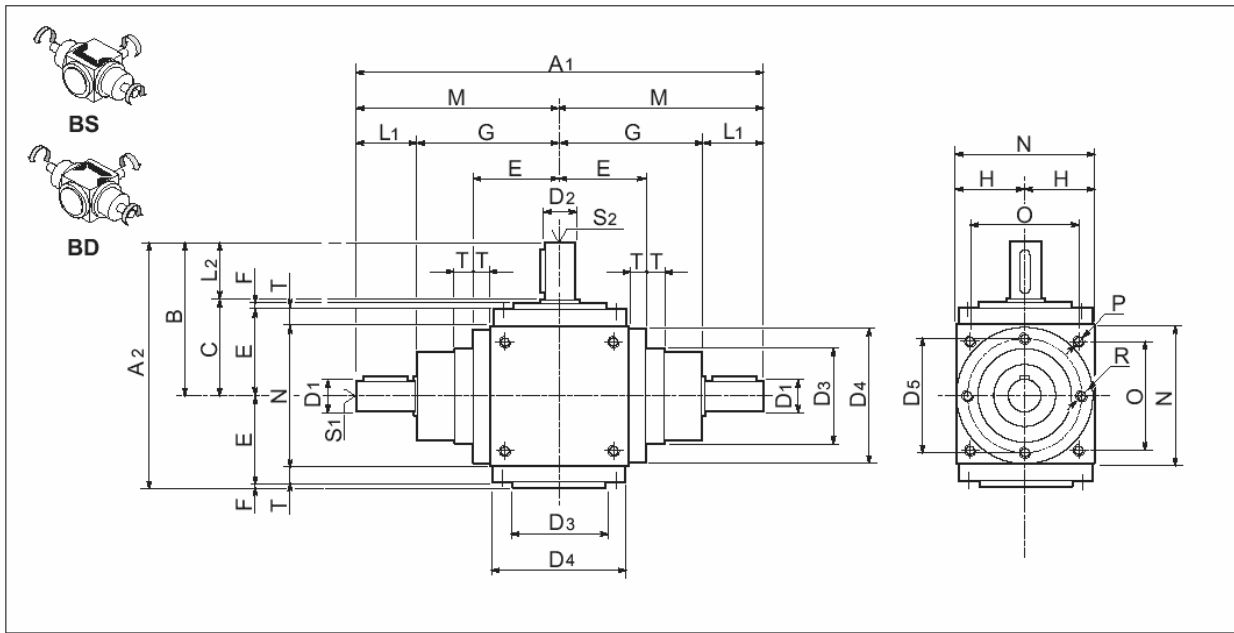

### Z.MBS - Z.MBD

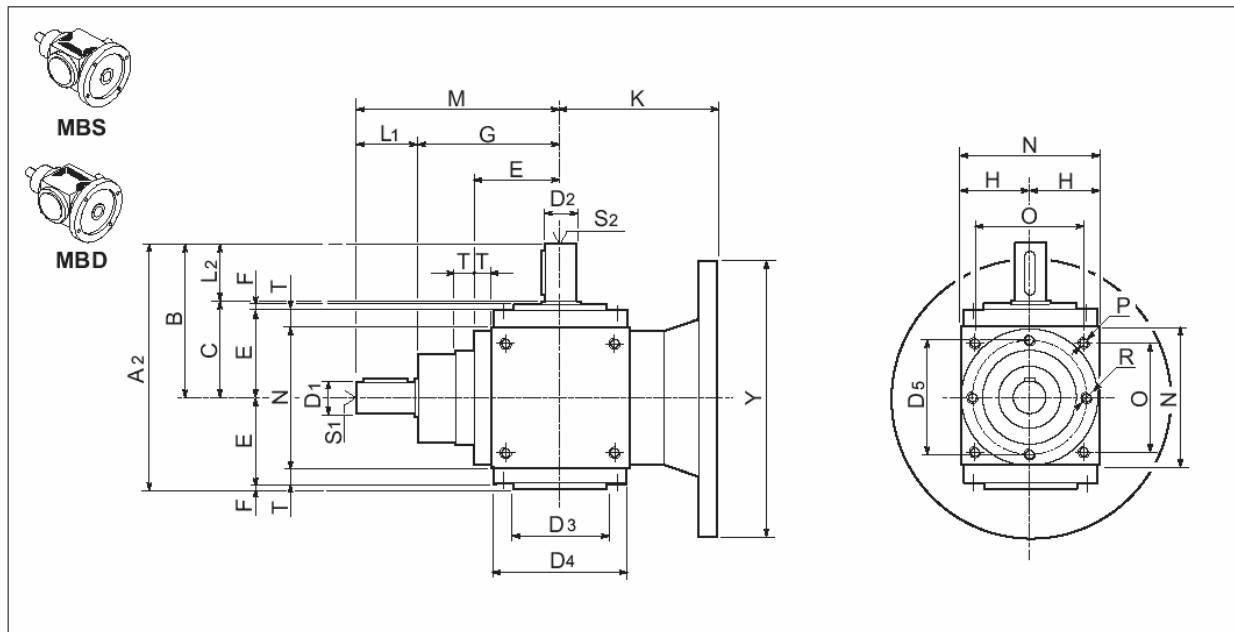



Z.BS Z.BD	C	D3 h8	D4	D5	E	F	G	H	N	O	P	R	T
12	46	44	—	54	42	2	74	32.5	65	45	M6	M6	—
19	65	60	86	72	59	4	100	45	90	70	M6	M6	14
24	80	70	105	88	73	5	115	55	110	88	M8	M8	18
32	95	95	135	115	88	5	145	70	140	110	M10	M10	18
38	110	120	165	145	103	5	170	85	170	136	M12	M12	18
42	125	135	190	165	118	5	195	100	200	155	M12	M12	18
55	150	170	230	205	143	5	245	120	240	190	M14	M14	23
75	225	—	300	—	195	—	350	165	330	248	M16	M16	30

Z.BS Z.BD	ir	A1	A2	M	Входной вал			Выходной вал		
					D1 j6	L1	S1	D2 j6	L2	S2
12	1-2-3	200	116	100	12	26	M4x8	12	26	M4x8
19	1-2-3	280	168	140	19	40	M6x12	19	40	M6x12
	4-5	260		130	14	30	M5x10			
24	1-2-3	330	208	165	24	50	M8x16	24	50	M8x16
	4-5	310		155	19	40	M6x12			
32	1-2-3	410	248	205	32	60	M10x20	32	60	M10x20
	4-5	390		195	24	50	M8x16			
38	1-2-3	480	288	240	38	70	M12x24	38	70	M12x24
	4-5	460		230	28	60	M10x20			
42	1-2-3	550	328	275	42	80	M12x24	42	80	M12x24
	4-5	510		255	32	60	M10x20			
55	1-2-3	710	408	355	55	110	M14x28	55	110	M14x28
	4-5	650		325	42	80	M12x24			
75	1-2-3	1000	598	500	75	150	M16x32	75	150	M16x32
	4-5	920		460	55	110	M14x28			

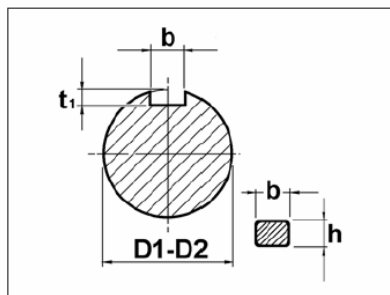

D1 - D2	b x h	t <sub>1</sub>
12	4 x 4	2.5
14	5 x 5	3.0
19	6 x 6	3.5
24	8 x 7	4.0
28	8 x 7	4.0
32	8 x 7	4.0
38	10 x 8	5.0
42	12 x 8	5.0
55	16 x 10	6.0
75	22 x 14	9.0

Z.MBS Z.MBD	IEC	12		19		24		32		38		42		55	
		Y	K	Y	K	Y	K	Y	K	Y	K	Y	K	Y	K
	B5	105 (B14)	90	140	90	160	120	200	140	200	155	250	200	250	220
		140	90	160	90	200	120	250	140	250	155	300	200	300	220
										300	155	350	200	350	220

### Z.AH

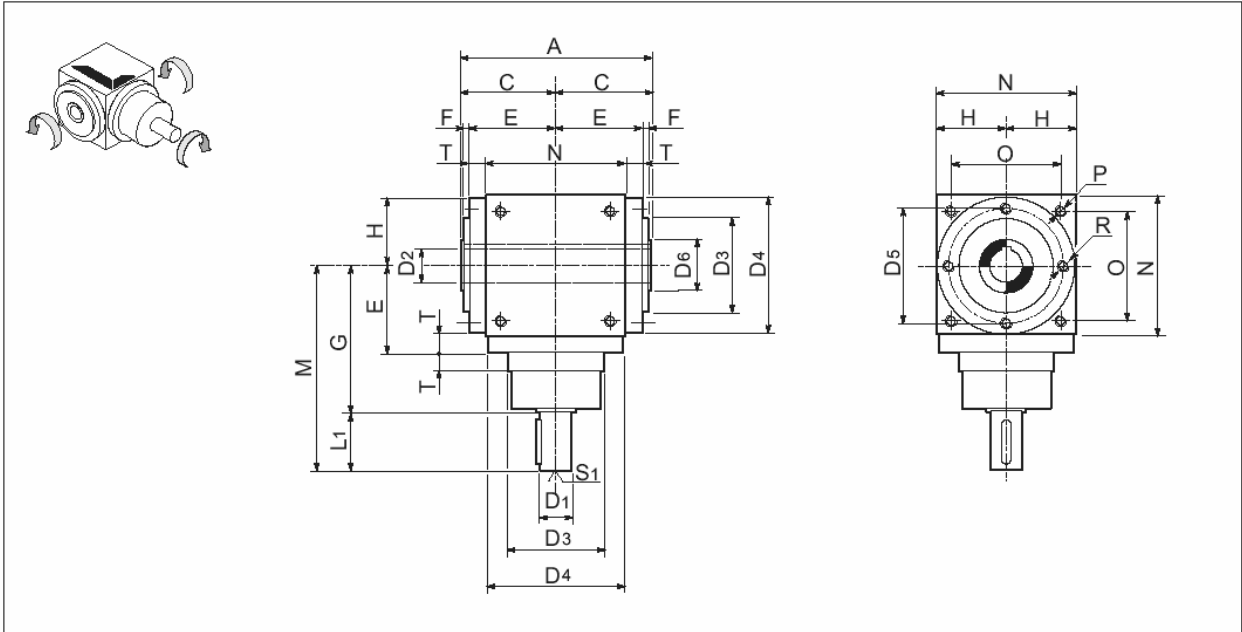

### Z.MAH

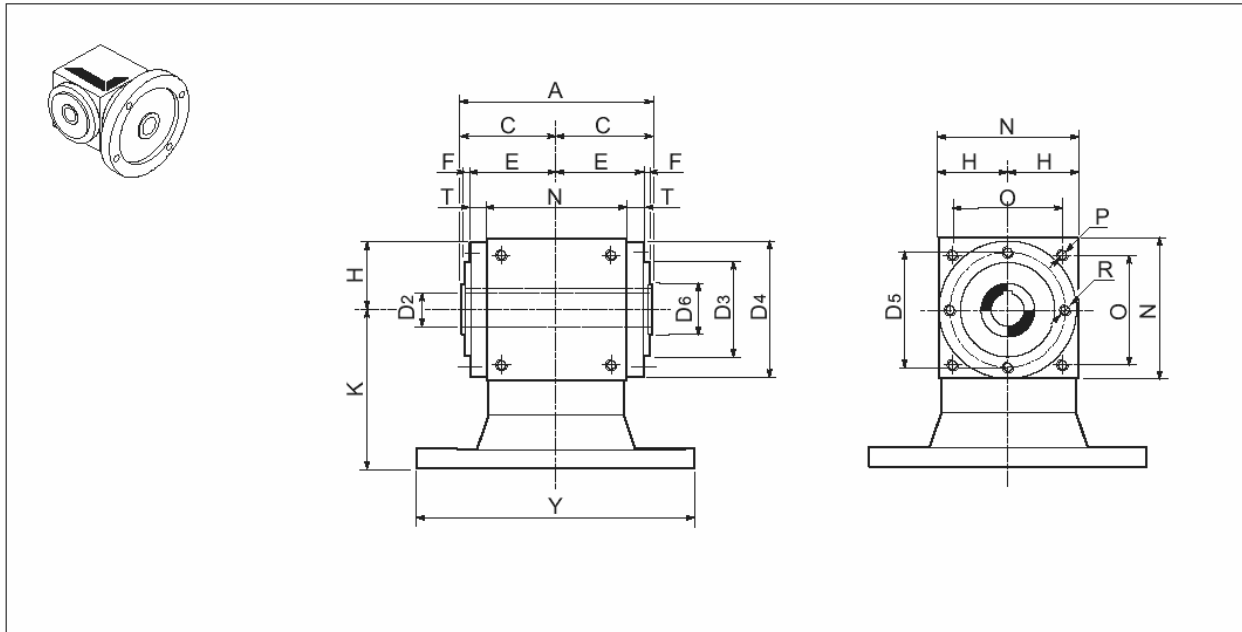



Z.AH	C	D3 h8	D4	D5	D6	E	F	G	H	N	O	P	R	T
12	46	44 (h7)	65	54	—	42	2	74	32.5	65	—	—	76	9.5
19	65	60	86	72	30	59	4	100	45	90	70	M6	M6	14
24	80	70	105	88	35	73	5	115	55	110	88	M8	M8	18
32	95	95	135	115	50	88	5	145	70	140	110	M10	M10	18
38	110	120	165	145	60	103	5	170	85	170	136	M12	M12	18
42	125	135	190	165	60	118	5	195	100	200	155	M12	M12	18
55	150	170	230	205	75	143	5	245	120	240	190	M14	M14	23
75	225	—	300	—	120	195	—	350	165	330	248	M16	M16	30

Z.AH	ir	A	M	Входной вал			Выходной вал
				D1 j6	L1	S1	D2 H7
12	1-2-3	92	100	12	26	—	12
19	1-2-3	130	140	19	40	M6x12	19
	4-5		130	14	30	M5x10	
24	1-2-3	160	165	24	50	M8x16	24
	4-5		155	19	40	M6x12	
32	1-2-3	190	205	32	60	M10x20	32
	4-5		195	24	50	M8x16	
38	1-2-3	220	240	38	70	M12x24	38
	4-5		230	28	60	M10x20	
42	1-2-3	250	275	42	80	M12x24	42
	4-5		255	32	60	M10x20	
55	1-2-3	300	355	55	110	M14x28	55
	4-5		325	42	80	M12x24	
75	1-2-3	450	500	75	150	M16x32	75
	4-5		460	55	110	M14x28	

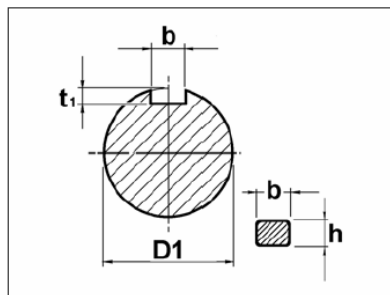

D1	b x h	t <sub>1</sub>
14	5 x 5	3.0 <sup>+0.1</sup>
19	6 x 6	3.5 <sup>0</sup>
24	8 x 7	4.0
28	8 x 7	4.0
32	8 x 7	4.0
38	10 x 8	5.0 <sup>+0.2</sup>
42	12 x 8	5.0 <sup>0</sup>
55	16 x 10	6.0
75	22 x 14	9.0

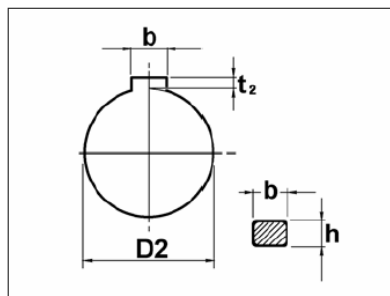

D2	b x h	t <sub>2</sub>
19	6 x 6	2.8 <sup>+0.1</sup>
24	8 x 7	3.3 <sup>0</sup>
32	8 x 7	3.3
38	10 x 8	3.3 <sup>+0.2</sup>
42	12 x 8	3.3 <sup>0</sup>
55	16 x 10	4.3
75	22 x 14	5.4

Z.MAH	IEC	12		19		24		32		38		42		55	
		Y	K	Y	K	Y	K	Y	K	Y	K	Y	K	Y	K
	B5	105 (B14)	90	140	90	160	120	200	140	200	155	250	200	250	220
		140	90	160	90	200	120	250	140	250	155	300	200	300	220
										300	155	350	200	350	220

### Z.BH

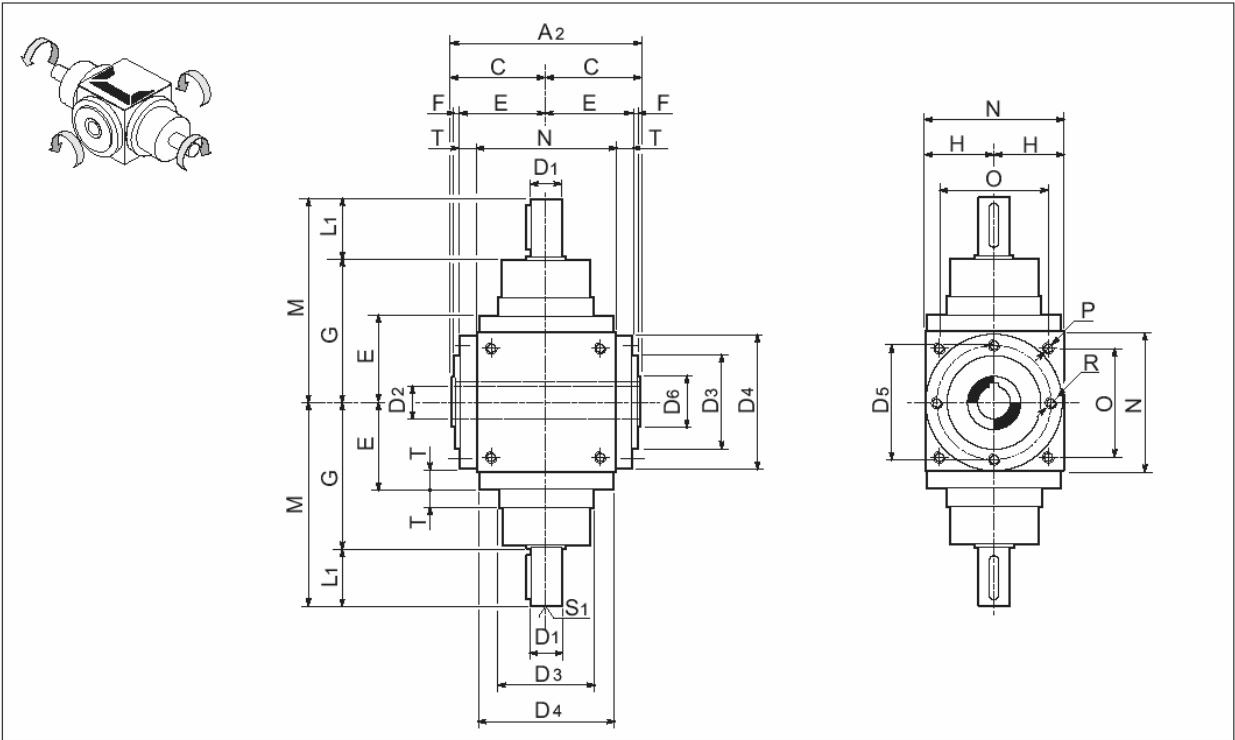

### Z.MBH

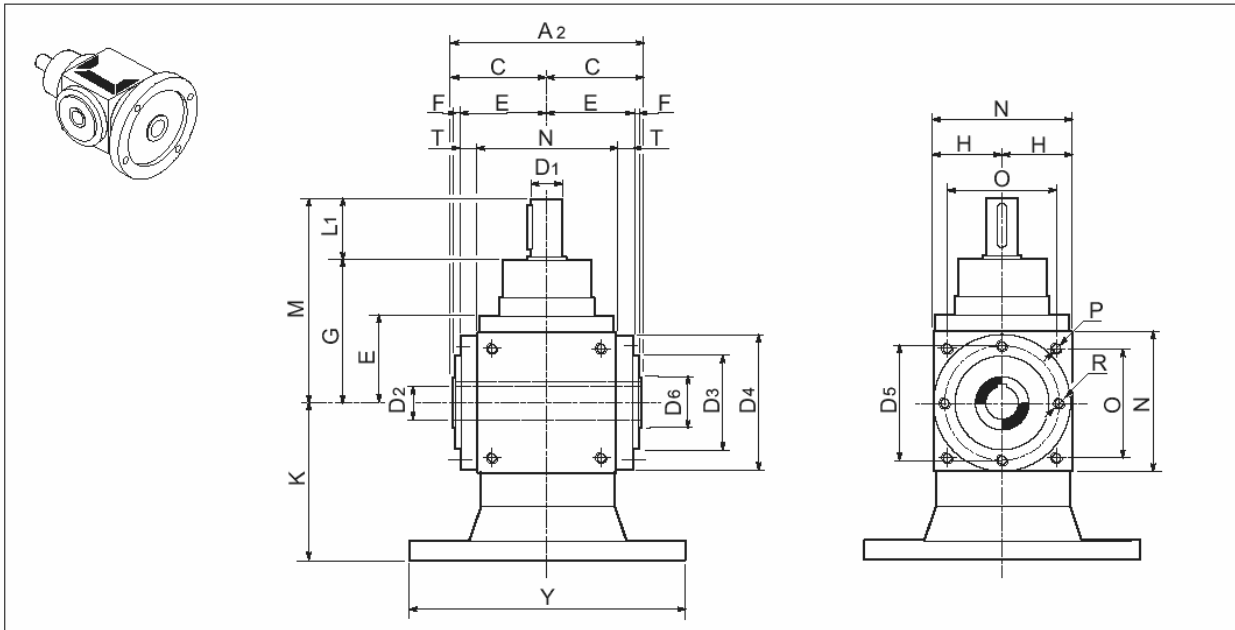



Z.BH	C	D3 h8	D4	D5	D6	E	F	G	H	N	O	P	R	T
12	46	44 (h7)	65	54	—	42	2	74	32.5	65	—	—	76	9.5
19	65	60	86	72	30	59	4	100	45	90	70	M6	M6	14
24	80	70	105	88	35	73	5	115	55	110	88	M8	M8	18
32	95	95	135	115	50	88	5	145	70	140	110	M10	M10	18
38	110	120	165	145	60	103	5	170	85	170	136	M12	M12	18
42	125	135	190	165	60	118	5	195	100	200	155	M12	M12	18
55	150	170	230	205	75	143	5	245	120	240	190	M14	M14	23
75	225	—	300	—	120	195	—	350	165	330	248	M16	M16	30

Z.BH	ir	A1	A2	M	Входной вал			Выходной вал	
					D1 j6	L1	S1	D2 H7	
12	1-2-3	—	—	—	—	—	—	—	—
19	1-2-3	280	130	140	19	40	M6x12	19	
	4-5	260		130	14	30	M5x10		
24	1-2-3	330	160	165	24	50	M8x16	24	
	4-5	310		155	19	40	M6x12		
32	1-2-3	410	190	205	32	60	M10x20	32	
	4-5	390		195	24	50	M8x16		
38	1-2-3	480	220	240	38	70	M12x24	38	
	4-5	460		230	28	60	M10x20		
42	1-2-3	550	250	275	42	80	M12x24	42	
	4-5	510		255	32	60	M10x20		
55	1-2-3	710	300	355	55	110	M14x28	55	
	4-5	650		325	42	80	M12x24		
75	1-2-3	1000	450	500	75	150	M16x32	75	
	4-5	920		460	55	110	M14x28		

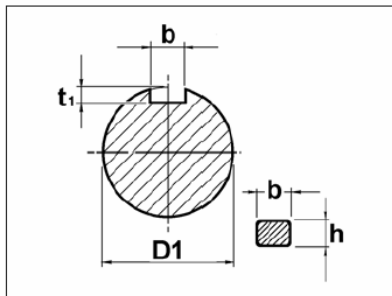

D1	b x h	t <sub>1</sub>
14	5 x 5	3.0 <sup>+0.1</sup> <sub>0</sub>
19	6 x 6	3.5 <sup>+0.1</sup> <sub>0</sub>
24	8 x 7	4.0 <sup>+0.2</sup> <sub>0</sub>
28	8 x 7	4.0 <sup>+0.2</sup> <sub>0</sub>
32	8 x 7	4.0 <sup>+0.2</sup> <sub>0</sub>
38	10 x 8	5.0 <sup>+0.2</sup> <sub>0</sub>
42	12 x 8	5.0 <sup>+0.2</sup> <sub>0</sub>
55	16 x 10	6.0 <sup>+0.2</sup> <sub>0</sub>
75	22 x 14	9.0 <sup>+0.2</sup> <sub>0</sub>

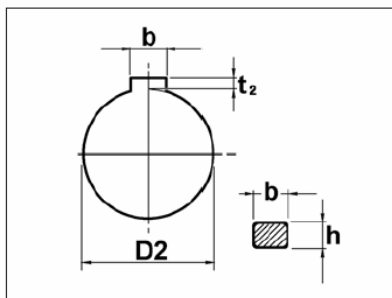

D2	b x h	t <sub>2</sub>
19	6 x 6	2.8 <sup>+0.1</sup> <sub>0</sub>
24	8 x 7	3.3 <sup>+0.2</sup> <sub>0</sub>
32	8 x 7	3.3 <sup>+0.2</sup> <sub>0</sub>
38	10 x 8	3.3 <sup>+0.2</sup> <sub>0</sub>
42	12 x 8	3.3 <sup>+0.2</sup> <sub>0</sub>
55	16 x 10	4.3 <sup>+0.2</sup> <sub>0</sub>
75	22 x 14	5.4 <sup>+0.2</sup> <sub>0</sub>

Z.MBH	IEC	12		19		24		32		38		42		55	
		Y	K	Y	K	Y	K	Y	K	Y	K	Y	K	Y	K
	B5	105 (B14)	90	140	90	160	120	200	140	200	155	250	200	250	220
		140	90	160	90	200	120	250	140	250	155	300	200	300	220
										300	155	350	200	350	220

### 5.9 Аксессуары

#### СОЕДИНИТЕЛЬНЫЙ ФЛАНЕЦ ТИПА FC

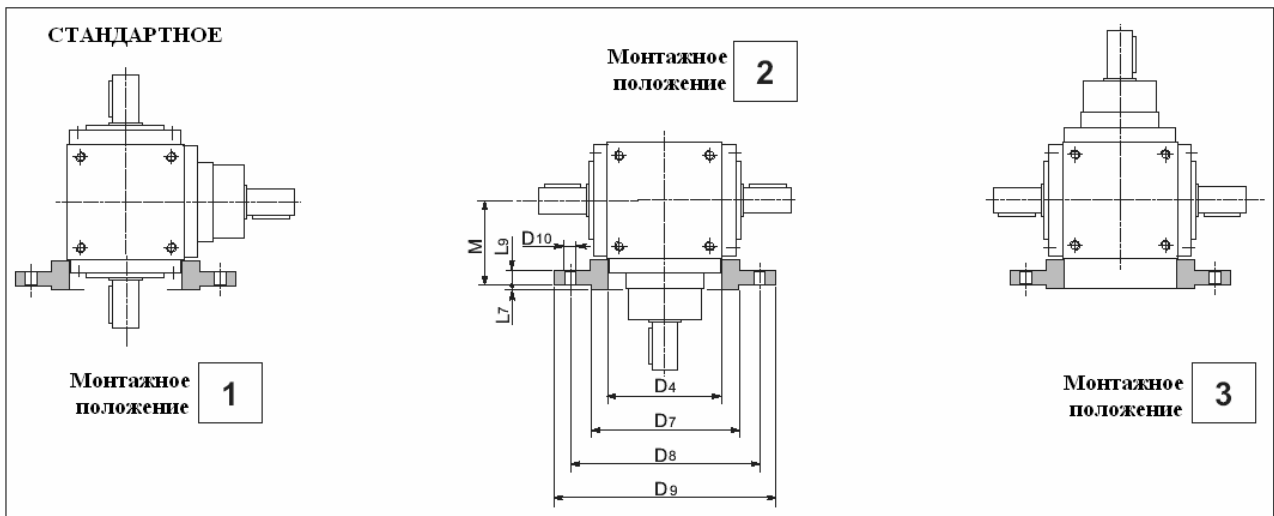

#### СОЕДИНИТЕЛЬНЫЙ ФЛАНЕЦ ТИПА FP

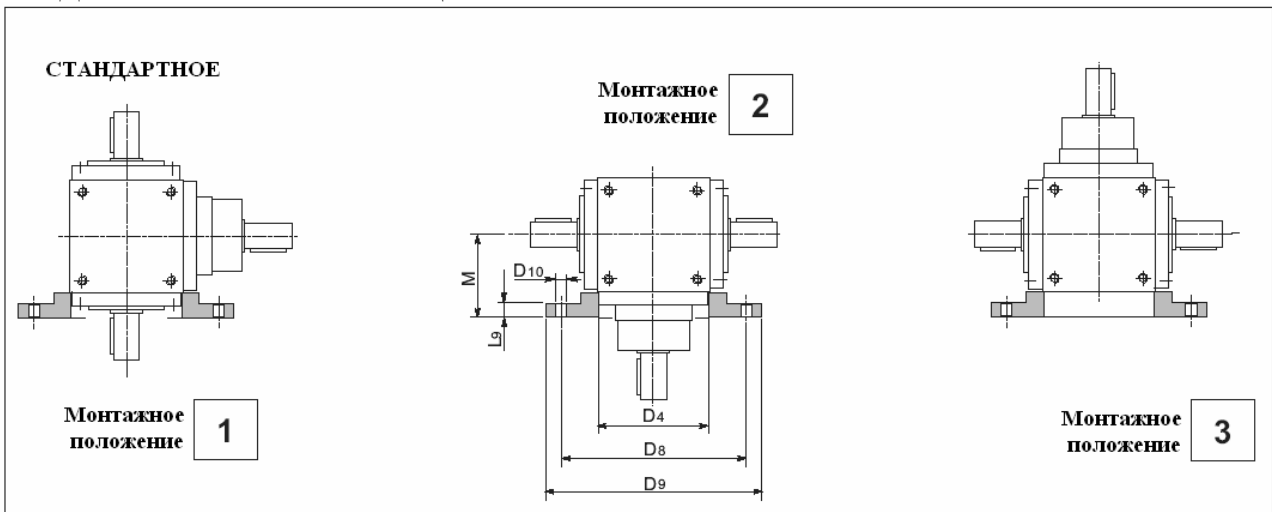

Z.	D4 h8	D7 h8	D8	D9	D10	L7	L9	M
12	—	—	—	—	—	—	—	—
19	86	110	130	160	9	3.5	12	70
24	105	130	165	200	11	3.5	13	85
32	135	180	215	250	14	4	15	105
38	165	230	265	300	14	4	15	125
42	190	230	265	300	14	4	15	145
55	230	250	300	350	18	5	18	175
75	300	350	400	450	18	5	25	230